



An EFCO Company

SWAPLOADER[®]

"Hooked on Quality"

U.S.A. LTD.

MODEL SL-520X

PARTS AND INSTALLATION MANUAL

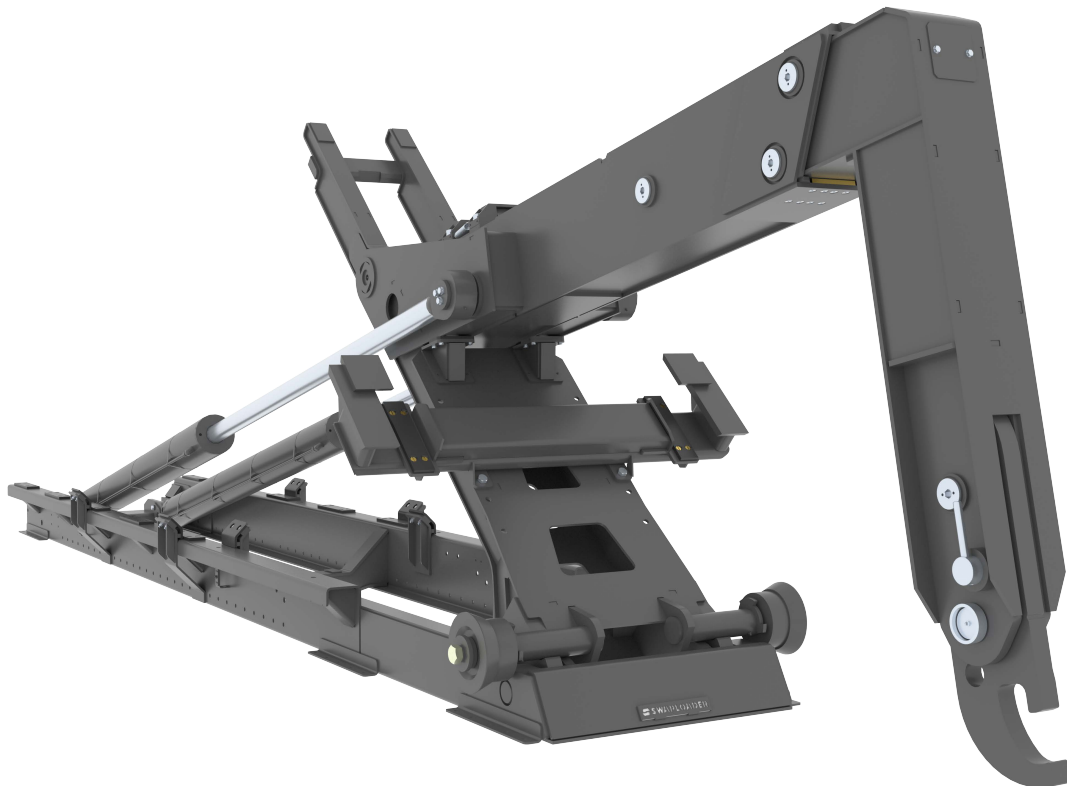

HOIST SERIAL NUMBER

TABLE OF CONTENTS

I. <u>INTRODUCTION</u>	
Letter to Customer	1-1
II. <u>INSTALLATION</u>	
Initial Inspection	2-1
General Installation Procedure	2-1
Hoist Installation to Truck Chassis	2-2
Controls Installation – Air Shift	2-5
Air Control Installation w/ U-Lock or O-Lock (Option)	2-6
Pump Installation	2-7
Hydraulic Tank Installation	2-8
Start Up Procedure	2-9
Stabilizer Installation (Option)	2-10
III. <u>PARTS</u>	
Base Hoist w/ Fixed Jib Assembly	3-1
Main Frame Sub-Assembly	3-2
Pivot Joint Sub-Assembly	3-3
Outer Tube Sub-Assembly	3-4
Pivot Lock (Mast Lock) Sub-Assembly	3-5
Body Lock w/ Shelf Assembly	3-6
Fixed Jib Sub-Assembly	3-7
Hoist Installation Kit	3-8
Base Cylinder Circuit	3-9
Tank Circuit	3-10
Pump Circuit	3-11
Air Controls, 2-Section	3-12
Decal Assembly	3-14
IV. <u>OPTIONS</u>	
Adjustable Jib Sub-Assembly	4-1
Cylinder Circuit, UL X-HD STD	4-2
U-Lock Assembly	4-3
Cylinder Circuit, OL X-HD STD	4-4
O-Lock Assembly	4-5
Air Controls, 3-Section	4-6
Tank Circuit, 3-Section 520X	4-8
Dual Rear Roller Assembly	4-9
Stabilizer Assembly	4-10
Stabilizer Circuit	4-11



This Page Intentionally Left Blank

TO THE CUSTOMER:

THIS MANUAL CONTAINS INSTALLATION INSTRUCTIONS TO THE TRUCK CHASSIS. ALL INSTRUCTIONS ARE RECOMMENDED PROCEDURES ONLY. THIS MANUAL ALSO PROVIDES BREAKDOWNS OF EACH SUB-ASSEMBLY APART OF THE HOIST THAT LISTS PART NUMBERS AND DESCRIPTIONS SHOULD ANYTHING NEED TO BE REPLACED ON THE HOIST. EACH SECTION IS CLEARLY IDENTIFIED SO YOU CAN EASILY FIND THE INFORMATION THAT YOU NEED. READ THE TABLE OF CONTENTS TO LEARN WHERE EACH SECTION IS LOCATED.



Throughout this manual you will come across "**Dangers,**" "**Warnings,**" or "**Cautions**" which will be carried out in bold type and preceded by the symbol as indicated to the left. Be certain to carefully read the message that follows to avoid the possibility of personal injury or machine damage.

Record your SwapLoader Hoist serial number in the appropriate space provided on the title page. Your SwapLoader dealer needs this information to give prompt, efficient service when ordering parts. It pays to rely on an authorized SwapLoader Distributor for your service needs. For the location of the Distributor nearest you, contact SwapLoader.

Also, included with your hoist, is a Technical Guide. This guide provides safety suggestions, technical information, operation instructions, maintenance requirements, troubleshooting, and accessory installation instructions. Please refer to the Technical Guide for any questions you may have pertained to the above.

NOTE: It is SwapLoader's policy to constantly strive to improve SwapLoader products. The information, specifications, and illustrations in this publication are based on the information in effect at the time of approval for printing and publishing. SwapLoader therefore reserves the right to make changes in design and improvements whenever it is believed the efficiency of the unit will be improved without incurring any obligations to incorporate such improvements in any unit which has been shipped or is in service. It is recommended that users contact an authorized SwapLoader Distributor for the latest revisions.

This Page Intentionally Left Blank

INSTALLATION

This Page Intentionally Left Blank

INITIAL INSPECTION

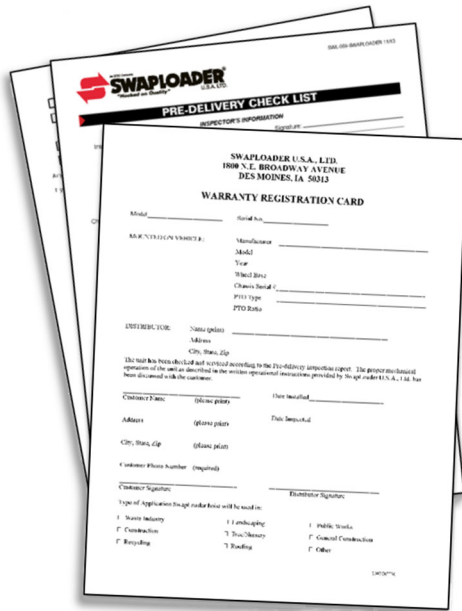

When the hoist is installed and ready for delivery, it is your responsibility to fill out and submit the Product Registration Form. Visit

<https://www.swaploader.com/warranty-registration/> to complete this form.

When the SwapLoader hoist is received from the factory, you should inspect the hoist for damage, which may have occurred in shipment. If damage has occurred, you should contact the shipper immediately. Be sure to note any damage or missing items on bill of Lading.

When you receive your SwapLoader hoist, it is your responsibility to make sure you have received all the parts and pieces that were ordered, within 30 days of the invoice date of the hoist. Lay out all the options, loose parts and accessories on a table and compare the items received vs the Packing List and the Loose Parts Box List(s) shipped with the hoist order.

If you have any problems, shortages, or questions, please contact SwapLoader U.S.A., Ltd. immediately.

GENERAL INSTALLATION PROCEDURE

The installation of the SwapLoader on a truck chassis will generally follow these steps:

1. Install hoist assembly onto truck chassis.
2. Mount the hydraulic control valve to the hoist and install the hydraulic plumbing from the control valve to the hydraulic cylinders. Then install the control levers in the cab and route the control cables to the hydraulic control valve assembly.
3. Install the hydraulic tank, hydraulic filter, and hydraulic plumbing between the hydraulic tank and the control valve assembly.
4. Select and install the P.T.O. on the truck transmission. (Note: This can be done prior to hoist installation on the truck chassis.)
5. Install the hydraulic pump and the plumbing from the pump to the hydraulic tank and control valve assembly.
6. Fill the hydraulic tank with oil, bleed the air from the pump suction line, and start up the unit.

Although SwapLoader attempts to include the mounts and attaching fasteners with each hoist unit, your installation may require some additional mounts or modifications. If you have problems with your installation, please contact SwapLoader at 1-888-767-8000, as we may be aware of another customer who has installed a SwapLoader on a similar truck chassis.

HOIST INSTALLATION TO TRUCK CHASSIS

1. Place the SL-520X hoist assembly on the truck chassis. The truck chassis mounting surface should be flat without any steps or protrusions. If necessary, shim bars need to be added to ensure a flat surface on which to support hoist. It is advised to clamp the main frame of the hoist to the truck chassis prior to install of the mount brackets.

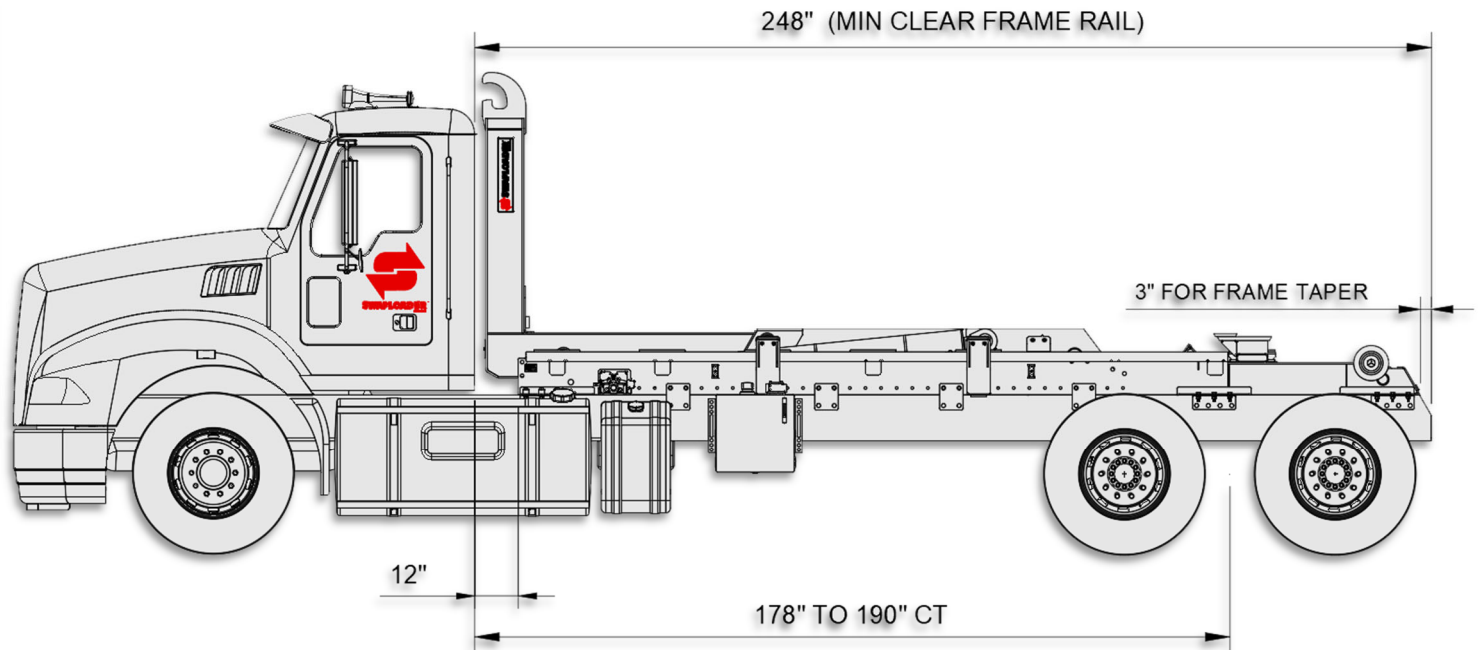

Figure A

The clear frame dimension indicated in *Fig. A* allows for the overall length of the hoist plus 5 inches for cab clearance and rear light bar mounting. Extra frame length may be needed to allow for mounting additional accessories (e.g., Cab Guard, Tarper, Light Kit, Stabilizer, etc.). For example, when mounting a light kit on a truck with a long CT, check that the hoist and the light kit are positioned far enough back to eliminate any interference between the fender and the light kit. You should also consider the final weight distribution regarding the bridge code when positioning the hoist.

NOTE:

THE ABOVE SPECIFICATIONS ARE A MINIMUM REQUIREMENT. IT IS THE RESPONSIBILITY OF THE OWNER/ OPERATOR TO ENSURE THE COMPLETED CHASSIS MEETS OR EXCEEDS ALL FEDERAL, STATE, AND LOCAL REGULATIONS. ALSO, THE HOIST SHOULD NOT BE USED TO LIFT AND HAUL ANY LOAD THAT EXCEEDS THE LOAD RATING OF ANY OF THE INDIVIDUAL COMPONENTS OF THE COMPLETED CHASSIS (TIRES, AXLES, SUSPENSION, ETC.)

2. There are two types of mount brackets used on the Model SL-520X hoist as indicated in *Fig. B*. They are the angle brackets (*Pt. No. 77H19*), and the mid brackets (*Pt. No. 76H89*). Bolt the mount brackets to the side of the hoist as indicated in *Fig. B*. Adjust locations as necessary to miss chassis suspension, brackets, etc. When positioning the brackets allow for mounting the control valve assembly and the hydraulic tank. You should consult the truck chassis supplier for any limitations regarding drilling mount holes in the truck chassis frame rails. Typically, the holes must be at least $2\frac{3}{4}$ " from the top of the truck chassis rails but may vary (reference *Fig. C, D & E*). Once the locations of the mount brackets have been

determined, use the mount brackets as a template for marking the mounting holes in the truck chassis frame rails. Drill the $21/32$ " diameter holes required and attach the brackets to

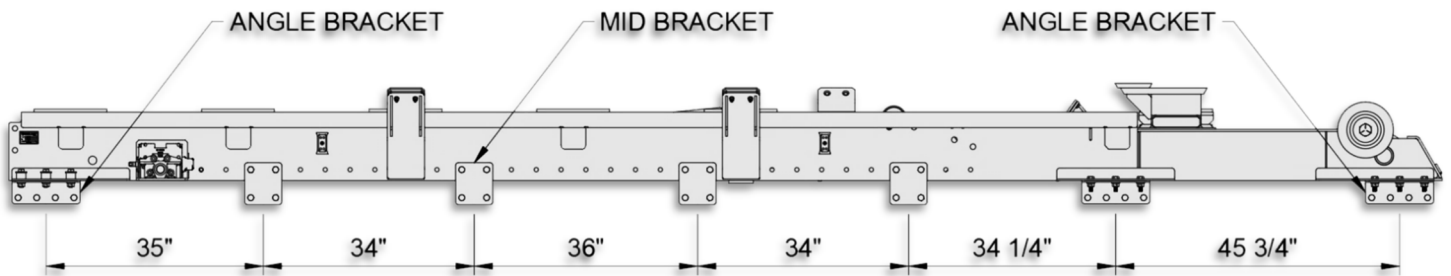

Figure B

the truck chassis with the $5/8$ " diameter bolts, washers, and locking hex nuts provided. Torque to 220 ft.lb.

3. Fasten the mount brackets to the hoist main frame as indicated on *Fig. C and Fig. D*. You may need to modify the mount brackets or add shim plates to allow for variances in the width of the truck chassis as well as to allow for top rivets, stepped channels, etc.

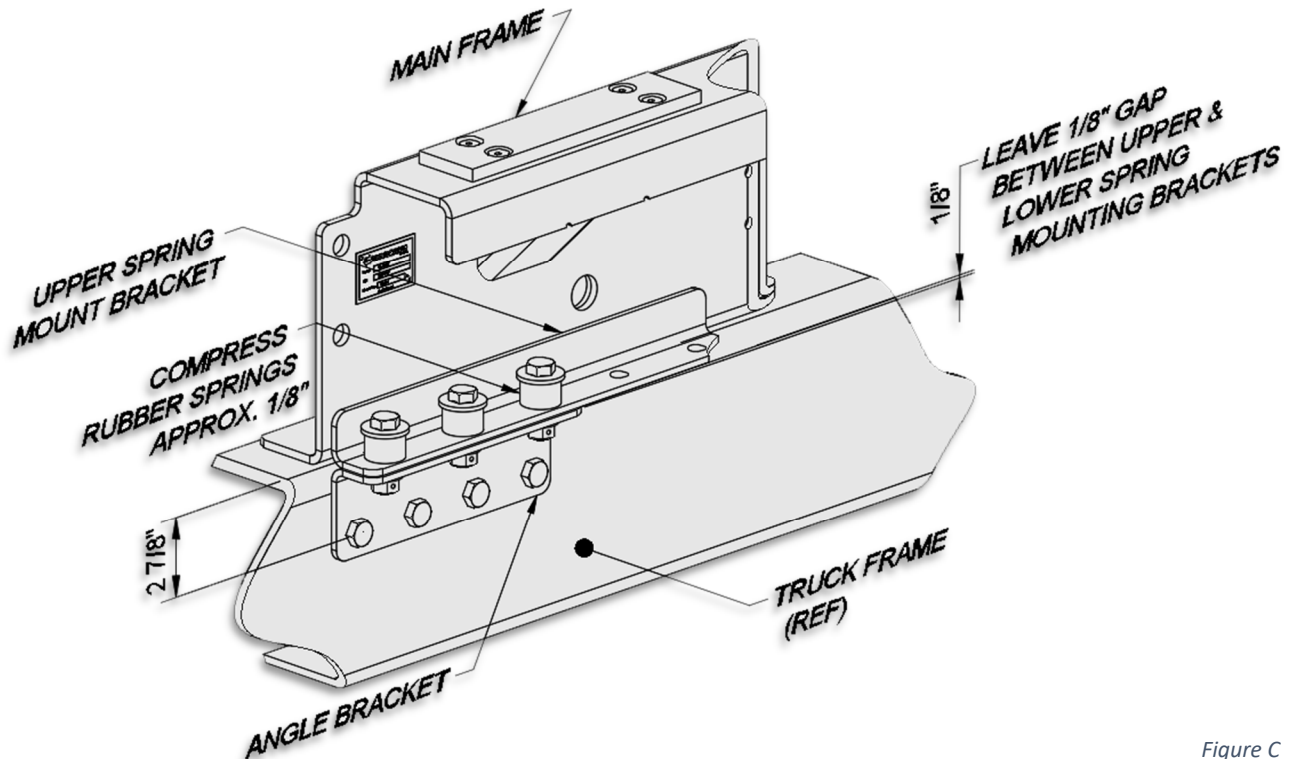

Figure C

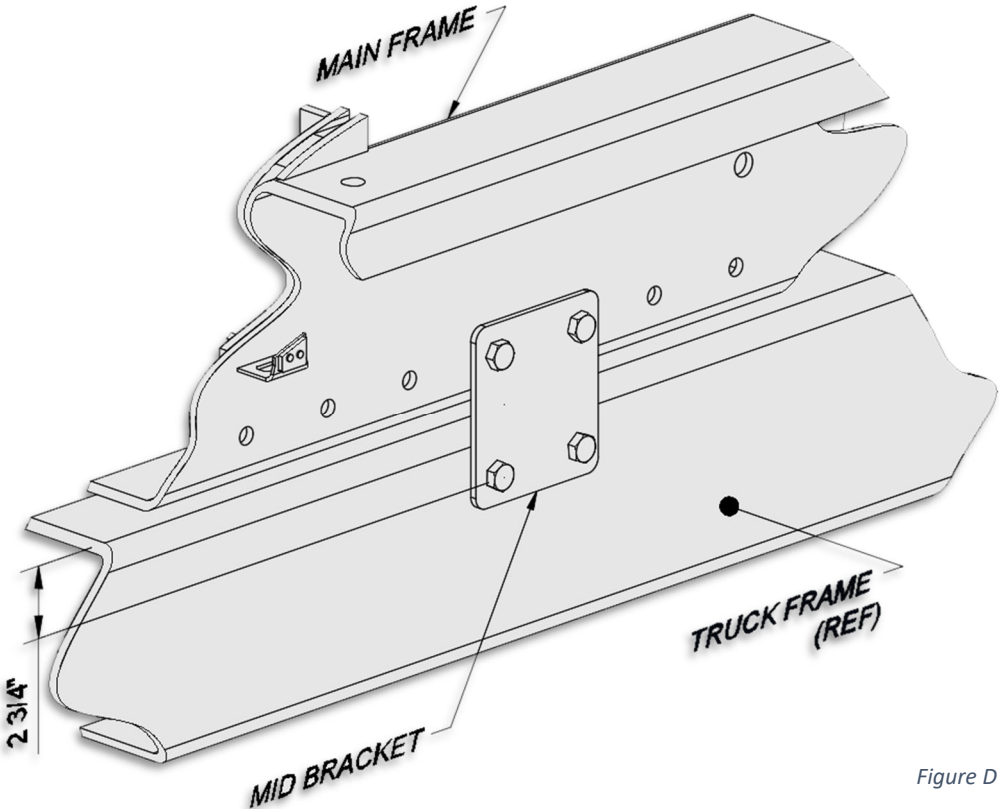

Figure D

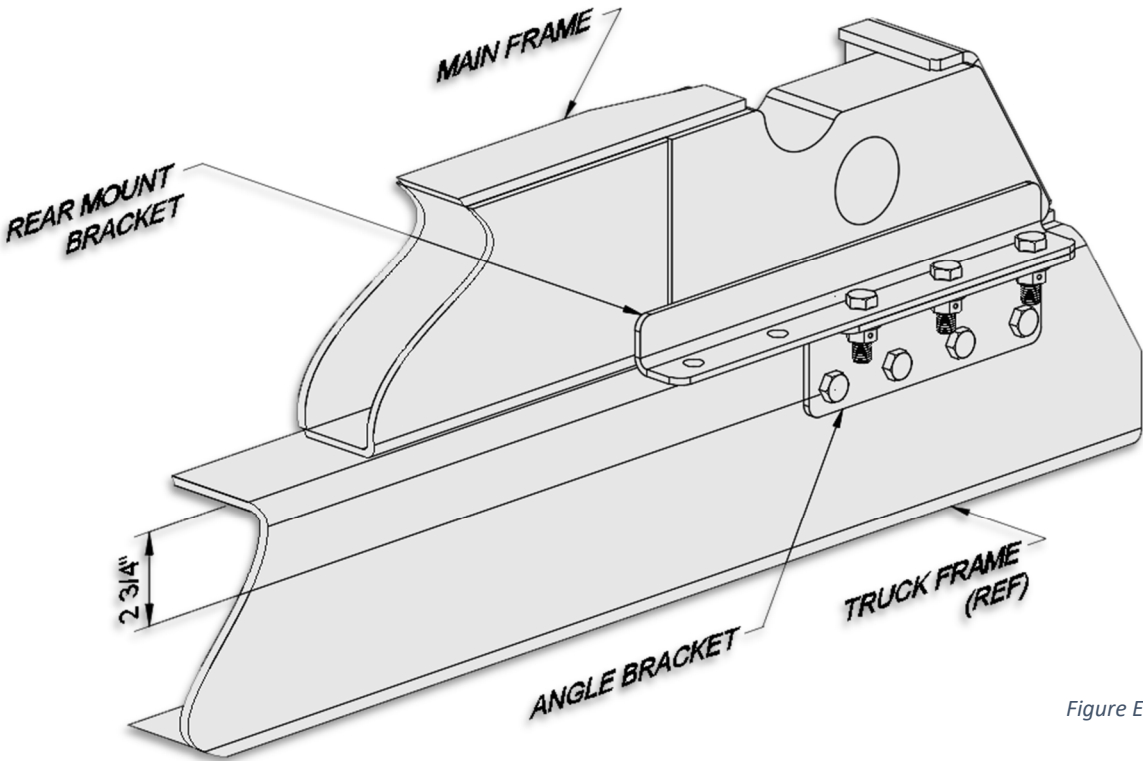
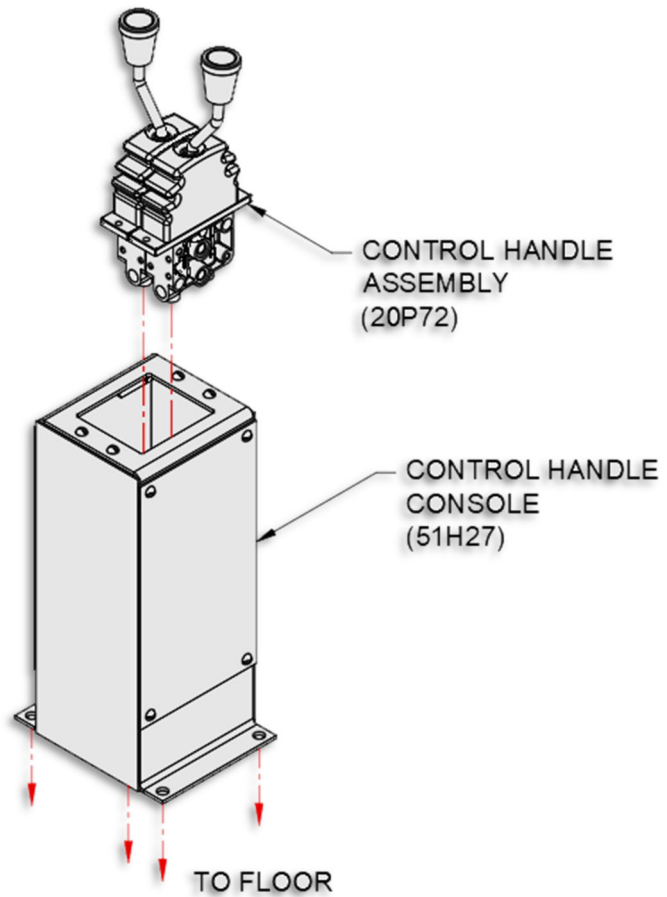

Figure E

CONTROLS INSTALLATION - AIR SHIFT

1. Attach the valve mount bracket to the main frame as indicated on *Pg. 3-12* with the fasteners provided.
2. Mount the hydraulic control valve assembly (*Pt. No. 23P21*) to the valve mount bracket as shown on *Pg. 3-12* with the fasteners provided.
3. Install the hydraulic adapters and connect the hydraulic hoses (*Pt. Nos. 14P39, 14P40, & 14P69*) to the control valve assembly as indicated on *Pg. 3-10*.
4. Determine the best location in the cab for the control handle assembly (*Pt. No. 20P72*). The location should be such that the controls can be easily reached while operating the truck. A control handle console (*Pt. No. 51H27*) is provided to facilitate the mounting of the control handles (see diagram →).
5. Install the air fittings and hose as shown on *Pg. 3-13* (Air Circuit Plumbing Diagram). An air pressure protection valve (*Pt. No. 20P74*) is provided so you can tap into the truck's air supply without jeopardizing the integrity of the air system. The air hose is provided in a bulk length, which you can cut to length as required for running the air lines. Take care in routing the air lines and avoid hot areas such as exhaust pipes, etc.



AIR CONTROL INSTALLATION w/ U-LOCK OR O-LOCK (OPTION)

The Universal Body Lock (U-Lock) can be installed with a standard 3-section valve and operated from the cab (see *Pg. 4-2 or 4-4* for routing). A separate indicator light and harness will be provided to be installed in the truck cab. This will notify the operator when the U-Lock has been engaged or disengaged.

1. Review all directions and diagrams provided before starting installation.
2. Mount valve to the hoist's Main Frame and attach all hoses, hose clamp assemblies and fittings as shown on *Pg. 4-2 or 4-4*.
3. Mount Indicator Light Box in the truck cab where it will be clearly visible to the operator.
4. Route Indicator Light and Harness (*Pt. No. 40P60*) from the truck cab to the U-Lock/O-Lock cylinder.
5. Hardwire or plug in provided 12V adapter for indicator light.

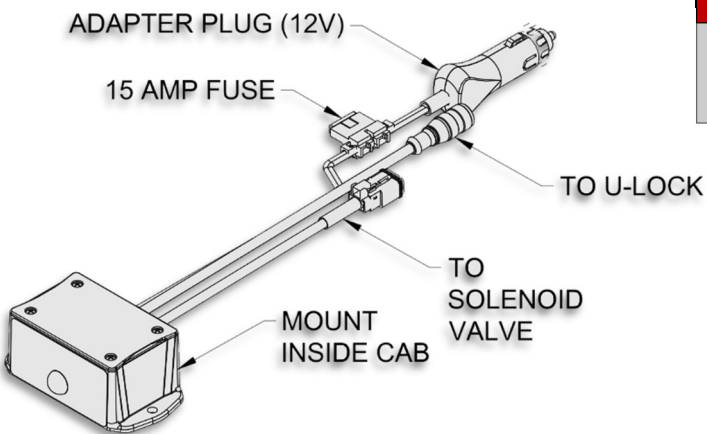
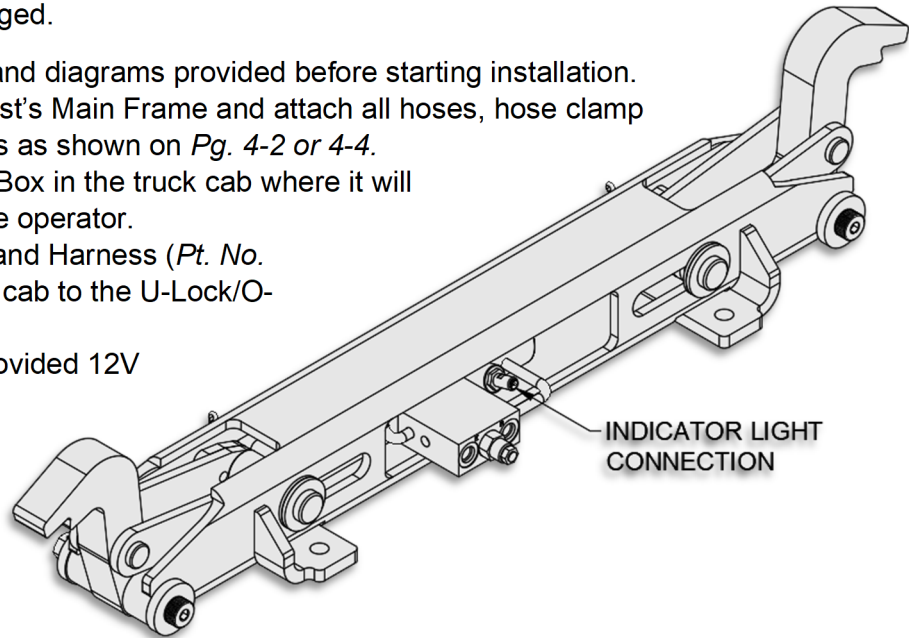

NOTE:

AS A SAFETY MEASURE, THE JIB CYLINDER IS DISENGAGED WHENEVER THE U-LOCK/O-LOCK IS ENGAGED.

PUMP INSTALLATION

1. Install the hydraulic pump to the P.T.O. (Bolts are not provided).
2. Install the hydraulic fittings into ports on the hydraulic pump as shown on *Pg. 3-11*.
3. Connect the suction hose assembly to the hydraulic tank (1-1/2" I.D. hose) and route to the hydraulic pump in as short and straight line as possible. Be sure to route the hose clear of exhaust components and of the drive shaft. Extra hose is provided so the hose can be shortened to an appropriate length. Install the hose on the hose barb fittings at the tank and at the pump and secure with the hose clamps provided.

NOTE: Prior to startup, this hose must be filled with oil.

4. The pressure hose from the hydraulic pump to the control valve assembly is not supplied with the hoist as it must be made to the proper length. This hose must be purchased from a local hydraulic hose assembly supplier per the following specification:
 - a. Hose ID: 3/4 inch
 - b. Working Pressure: 5000 PSI
 - c. Hose Fitting Threads: SAE O-Ring Face Seal 1 3/16-12
5. Install the pressure hose as indicated. Tie up the pressure and suction hoses as necessary. Again, be sure the hoses are routed to avoid exhaust components and to stay clear of the drive shaft.

NOTE:

THE ABOVE SPECIFICATIONS ARE A MINIMUM REQUIREMENT. IT IS THE RESPONSIBILITY OF THE OWNER/ OPERATOR TO ENSURE THE COMPLETED CHASSIS MEETS OR EXCEEDS ALL FEDERAL, STATE, AND LOCAL REGULATIONS. ALSO, THE HOIST SHOULD NOT BE USED TO LIFT AND HAUL ANY LOAD THAT EXCEEDS THE LOAD RATING OF ANY OF THE INDIVIDUAL COMPONENTS OF THE COMPLETED CHASSIS (TIRES, AXLES, SUSPENSION, ETC.)

HYDRAULIC TANK INSTALLATION

1. Select a location to mount the hydraulic tank. Reference *Fig. G* for the suggested location of the hydraulic tank to the rear of the control valve assembly on the left-hand side of the truck. The hydraulic hoses have been sized for the tank to be mounted in this general area. The tank can be located on the right-hand side or behind the cab, if necessary, which means longer hoses may be required.
2. Drill four (4) holes for 1/2" diameter bolts (provided) in the mount angle of the hydraulic tank (two per angle) and the frame rails of the truck chassis. Mount the hydraulic tank and install the hydraulic filter. Install the hydraulic return hose and the hose barb fitting as shown on *Pg. 3-11*. The hose length can be shortened if necessary. Secure the hose to the barb fittings with the hose clamps provided.

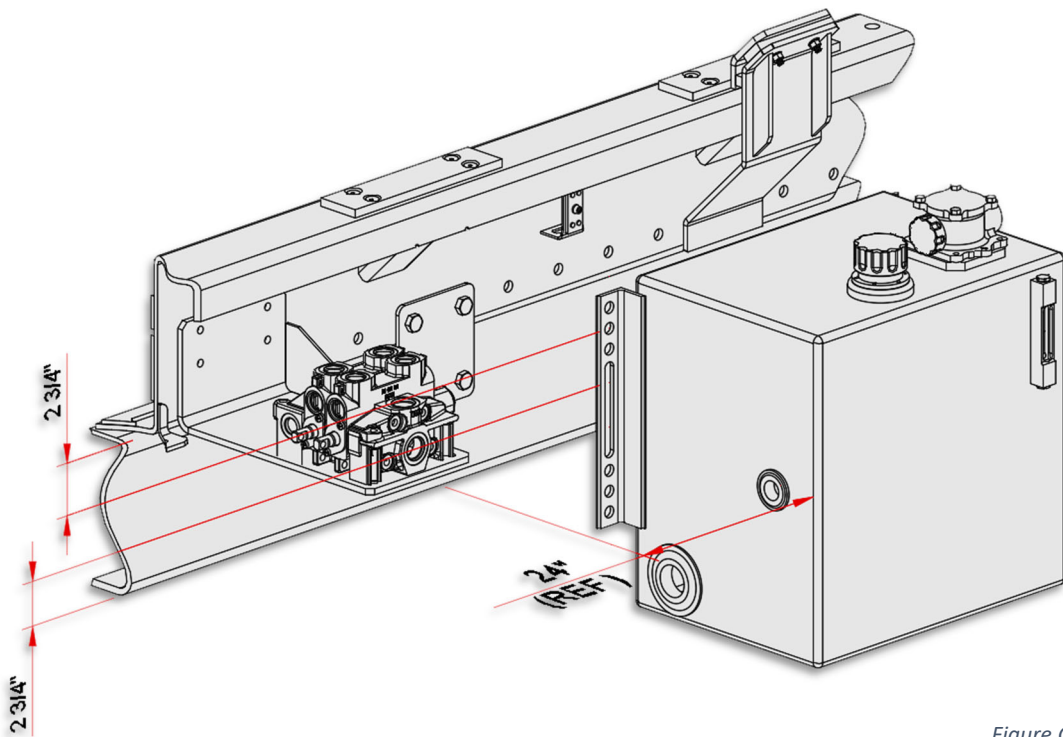
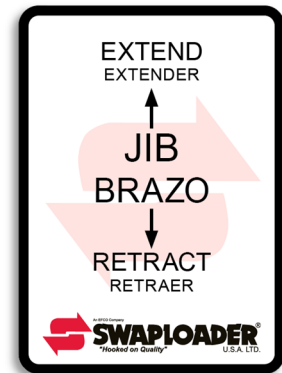
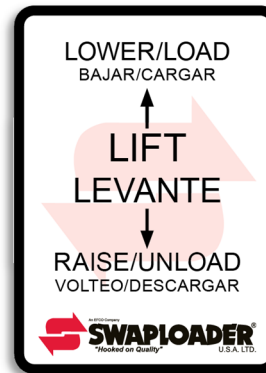

Figure G

START UP PROCEDURE

1. Fill the hydraulic tank with hydraulic oil (see oil specification in Section IV: Maintenance.)
2. Prime the pump by loosening the clamp on the suction hose at the pump. Pull the hose back off the fitting till the air is bled from the line. Push the hose back on the fitting and retighten the clamp.
3. Engage the P.T.O. and run the engine at idle (700 to 900 RPM). Operate the cylinders at full stroke five to ten times to bleed the air from the lines and cylinders. The cylinders were filled with oil during testing at the factory, but some seepage may have occurred during shipping and installation. Refill the hydraulic tank, if needed, during this sequence and do not let the pump run without oil.
4. Check for leaks and tighten fittings as necessary.
5. Verify the movement of the control levers corresponds to the movement of the cylinders per the figure below.
6. Install all safety decals and product decals as shown on *Pg. 3-14* after final installation and painting have been completed.
7. Fill out the Product Registration form online at <https://www.swaploader.com/warranty-registration/>.



NOTE:

FAILURE TO FILL OUT AND SUBMIT PRODUCT REGISTRATION WITHIN 15 DAYS OF INSTALLATION MAY POSSIBLY VOID THE WARRANTY.



- CAUTION** The SwapLoader hoist must be used with bodies or containers that properly fit the front hook and the rear hold-downs (see Subframe Critical Dimensions in the Technical Guide). If possible, pick up one of the containers that will be used with the SwapLoader hoist and verify the following:
- Outside dimensions of the long sills match the guiding rollers on the hoist.
 - The front hook dimensions are correct for the hoist.
 - The rear hold-downs of the container latch into the hold-downs on the hoist.
 - Check for any interference between the container and any part of the hoist (i.e.: Hydraulic tank, hydraulic tubing or hose, hydraulic valve, etc.)

STABILIZER INSTALLATION (OPTION)

1. The hoist installation for a unit with the stabilizer option is much the same as that for the standard unit except that a three-section hydraulic control valve is used (see Pg. 4-10 to 4-11 for the correct installation and plumbing diagrams for a hoist with three control circuits in the Option section of the manual).
2. The following diagram gives the approximate position of the stabilizer roller from the top of the truck chassis frame rail with the mounts as provided by SwapLoader. When extended down, the roller should touch the ground only when the vehicle is loading a heavy container. Therefore, with the truck empty, leave 2 to 3 inches of clearance between the ground and the roller. Also, you will need to check that when the roller is up in the transport position it does not interfere with any part of the rear axle, rear suspension, or brake components. If some interference will occur, you may slant the stabilizer mounting back from the vertical position until you leave enough clearance. This can be achieved by cutting the truck chassis frame rails off at an angle before installing the stabilizer mounts. Do not slant the mounting more than eight degrees (about a 14:2 pitch).
3. Once the required position of the stabilizer has been determined, install as shown on Pg. 4-10 in the Options section of the Parts & Installation manual (field weld size requirements are also indicated on this page).

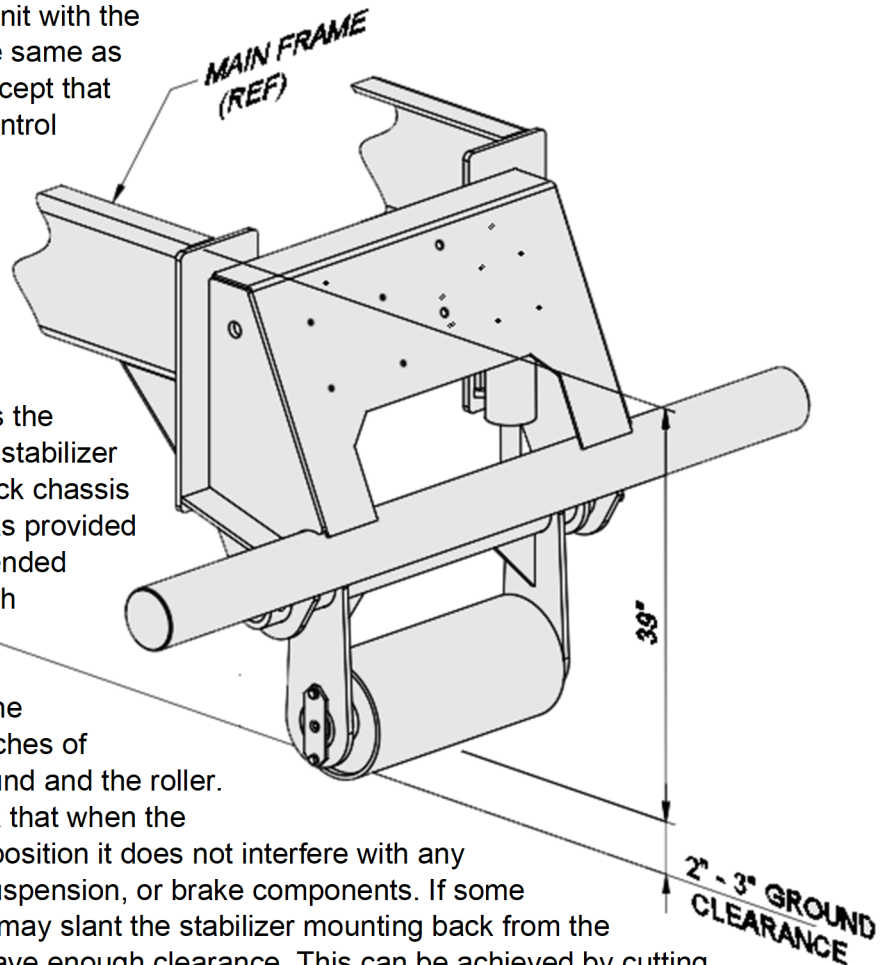

NOTE:

PRIOR TO ANY WELDING, CONSULT THE TRUCK MANUFACTURER FOR ANY SPECIAL PRECAUTIONS THAT MAY NEED TO BE TAKEN. TYPICALLY, THE BATTERIES MUST BE DISCONNECTED AND THE GROUND LEAD FROM THE WELDER SHOULD BE CONNECTED AS CLOSE AS POSSIBLE TO THE PART BEING WELDED TO AVOID THE POSSIBILITY OF ARCHING ACROSS BEARINGS, GEARS, ETC.

NOTE:

THE HOIST MAINFRAME IS MADE FROM HIGH STRENGTH LOW ALLOY STEEL. USE AN APPROPRIATE WELDING PROCESS.

4. Install the hydraulic adapters and hoses from the three-section hydraulic control valve to the hydraulic cylinder (*Pt. No. 21P84*) shown on Pg. 4-11 of the Parts & Installation manual. Tie up all loose hoses as required. Be sure the hoses are routed to avoid exhaust components and all moving components of the rear axles.

5. After the start procedure has been completed on the hoist, verify that the movement of each control lever corresponds to the movement of the cylinders per the figure below. Operate the stabilizer through 5 to 8 cycles to remove the air from the hydraulic cylinders and lines.

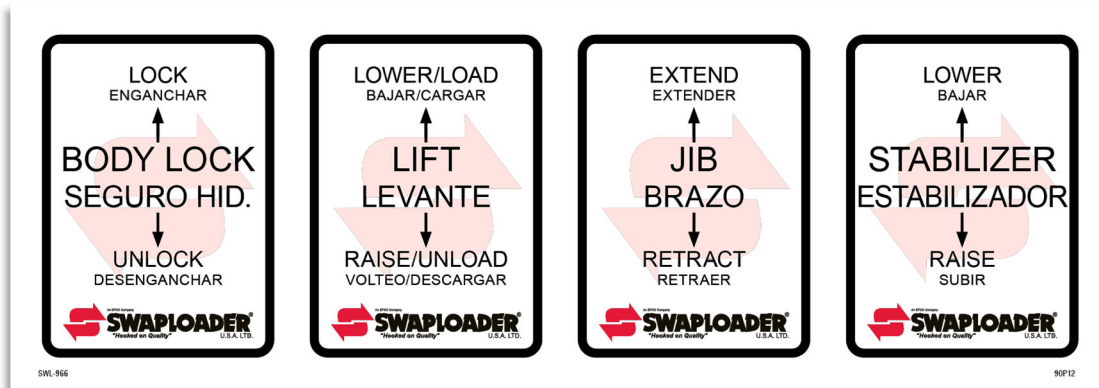

This Page Intentionally Left Blank

PARTS

This Page Intentionally Left Blank

HEX HEAD CAP SCREW TORQUE SPECS	
BOLT SIZE	SAE GR 8 W/ LOCK WASHER (FT-LBS)
3/8	53
7/16	85
1/2	130
5/8	258
3/4	459
7/8	739
1	1108

Note: Apply Loctite 243 (Blue) to all bolts.

45H01 - BASE HOIST ASSEMBLY				SL-520X	
ITEM	PART #	QTY	DESCRIPTION	WT-lb/ea.	WT-lb/all
1	45H03	1	Main Frame Sub-Assembly	2776.95	2776.95
2	45H08	1	Outer Tube Sub-Assembly	1101.31	1101.31
3	45H14	1	Fixed Jib Sub-Assembly	712.45	712.45
4	45H16	1	Pivot Joint Sub-Assembly	900.47	900.47
5	45H23	1	Body Lock w/Shelf, SL-520X	235.69	235.69
*	6	91H77	Base Cyl Circuit, 520X	51.54	51.54
7	00769	4	Washer, Lock 3/4	0.01	0.04
8	00P17	4	Nut, Hex 3/4-10 UNC Gr8	0.13	0.52
9	00P89	4	HHCS 3/4-10 UNC x 1-3/4 Gr8	0.33	1.32
10	90P90	1	Name Plate Insert	0.09	0.09

* Item not shown.

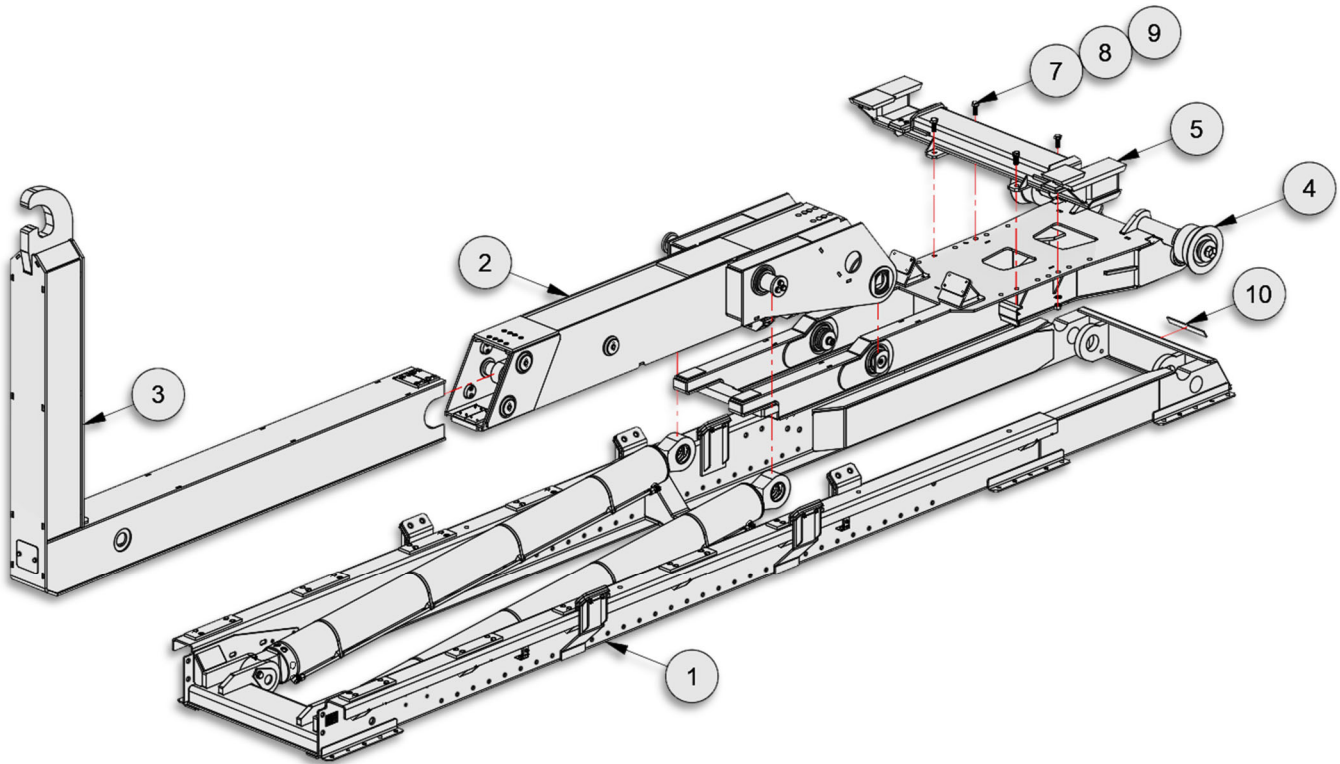

SL-520 BASE HOIST w/ FIXED JIB

HEX HEAD CAP SCREW TORQUE SPECS

BOLT SIZE	SAE GR 8 W/ LOCK WASHER (FT-LBS)
3/8	53
7/16	85
1/2	130
5/8	258
3/4	459
7/8	739
1	1108

Note: Apply Loctite 243 (Blue) to all bolts.

SOCKET HEAD CAP SCREW TORQUE SPECS

BOLT SIZE	SAE GR 8 W/ LOCK WASHER (FT-LBS)
3/8	62
7/16	103
1/2	151
5/8	291
3/4	516
7/8	831
1	1246

Note: Apply Loctite 243 (Blue) to all bolts.

45H03 – MAIN FRAME SUB-ASSEMBLY

SL-520X

ITEM	PART #	QTY	DESCRIPTION	WT-lb/ea.	WT-lb/all
1	42H01	2	Pin, MF/Cyl 3 x 5-3/4 ZP	12.93	25.86
2	42H49	1	Jib Lockout Mnt, 5 x 5 HD	2.61	2.61
3	45H04	1	Main Frame Wdmt, SL-520X	1532.24	1532.24
4	45H77	6	Front Guide Shim Wdmt, X-HD	3.63	21.78
5	00752	2	Washer, Lock 5/16	0.03	0.09
6	00755	54	Washer, Lock 3/8	0.03	1.38
7	00P14	52	Nut, Hex 3/8-16 UNC Gr8	0.02	0.48
8	00P32	2	SHCS 3/8-16 UNC x 1-1/4 Gr8	0.07	0.14
9	00P44	12	HHCS 3/8-16 UNC x 1-1/2 Gr8	0.07	0.28
10	00P56	2	HHCS 5/8-11 UNC x 1-1/2 Gr8	0.18	0.36
11	00P68	40	FHSS 3/8-16 UNC X 1-1/4 SS	0.11	0.07
12	01P20	1	SHCS 3/8-16 UNC x 1-3/4 Gr8	0.07	0.07
13	01P31	2	Washer, Disc Lock 5/8 Pr	0.03	0.15
14	10P63	2	HHCS 5/16-18 UNC x 1-3/4 ZP	0.03	0.10
15	23P17	2	Hyd Cyl 6x3x85.25	589.83	1622.80
16	90P71	10	Wear Pad, 2-3/4x1/2x11-3/4	0.70	7.00

LIFT CYLINDER SERVICE PARTS (quantity per cylinder)

17	22P78	2	C'Bal Cart, 5000 PSI CBCG-LJN	0.50	
18	22P96	2	Spherical Bearing	2.52	
19	23P41	1	Return Line	2.56	
20	23P42	1	Seal Kit, Cyl	0.02	

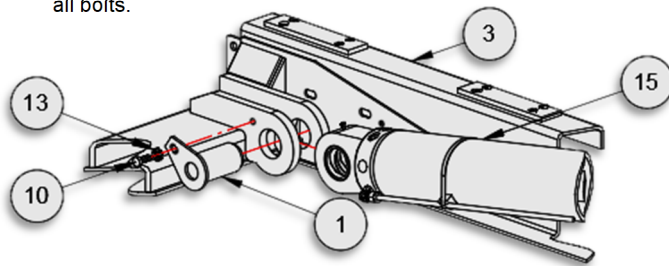

LIFT CYLINDER PIN DETAIL

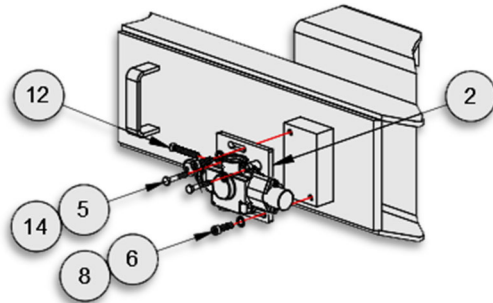

JIB LOCKOUT VALVE MOUNT DETAIL

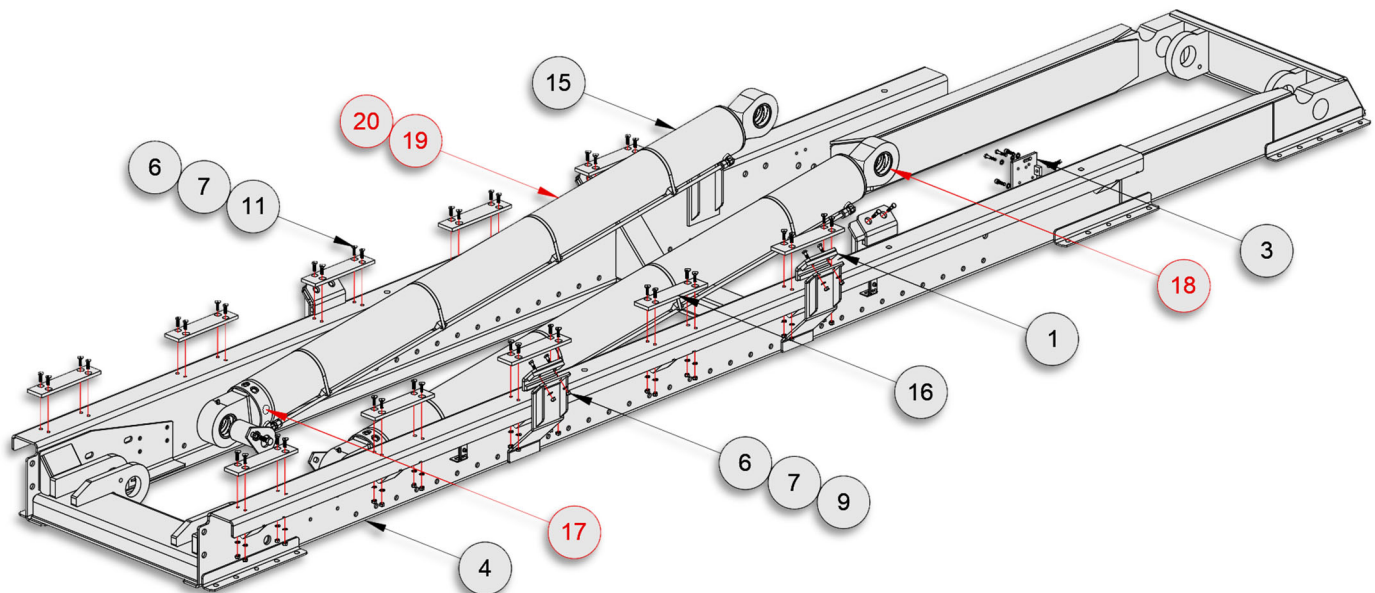

MAIN FRAME SUB-ASSEMBLY

HEX HEAD CAP SCREW TORQUE SPECS	
BOLT SIZE	SAE GR 8 W/ LOCK WASHER (FT-LBS)
3/8	53
7/16	85
1/2	130
5/8	258
3/4	459
7/8	739
1	1108

Note: Apply Loctite 243 (Blue) to all bolts.

SOCKET HEAD CAP SCREW TORQUE SPECS	
BOLT SIZE	SAE GR 8 W/ LOCK WASHER (FT-LBS)
3/8	62
7/16	103
1/2	151
5/8	291
3/4	516
7/8	831
1	1246

Note: Apply Loctite 243 (Blue) to all bolts.

45H16 – PIVOT JOINT SUB-ASSEMBLY				SL-520X	
ITEM	PART #	QTY	DESCRIPTION	WT-lb/ea.	WT-lb/all
1	40H84	2	Pin, PJ/MF 3 x 8	16.99	33.98
2	40H93	2	Roller Assy, Ø7x 2-1/2	41.78	83.56
3	43H79	2	Pin Cap, 3/4 x 4	1.42	2.84
4	43H80	2	Pin, PJ/OT 3 x 5-3/8	11.01	22.02
5	45H17	1	Pivot Joint Wdmt, SL-520X	735.14	735.14
6	76H80	2	Spacer, Roller 3-1/2 x 11/16	1.77	3.54
7	76H92	2	Top Plate, Tube Stop	1.83	3.66
8	77H06	2	Shim 3-1/4 x 22GA x 5-1/2	0.16	0.32
9	83H10	2	Spacer, Roller 11/16x2-13/16	0.90	1.80
10	00755	8	Washer, Lock 3/8	0.03	0.24
11	00P03	8	HHCS 3/8-16 UNC x 3/4 Gr8	0.04	0.32
12	00P56	2	HHCS 5/8-11 UNC x 1-1/2 Gr8	0.18	0.36
13	01P31	2	Washer, Disc Lock 5/8 Pr	0.03	0.06
14	01P32	2	Washer, Disc Lock 3/4 Pr	0.05	0.10
15	01P52	2	SHCS 3/4-10 UNC x 2	0.20	0.40
16	02P07	2	Washer, Disc Lock 1-1/4 Pr	0.10	0.20
17	14P22	2	HHCS 1-1/4-7 UNC x 2	1.30	2.60
18	90P03	6	Grease Zerk, 1/8-27 NPT Str	0.01	0.06
BUSHINGS (quantity per assembly)					
19	84H35	2	Brz Brg, 2.75IDx4.00x3.25OD		
20	50P20	4	Brz Brg, 3IDx3-7/16x3-3/4OD		

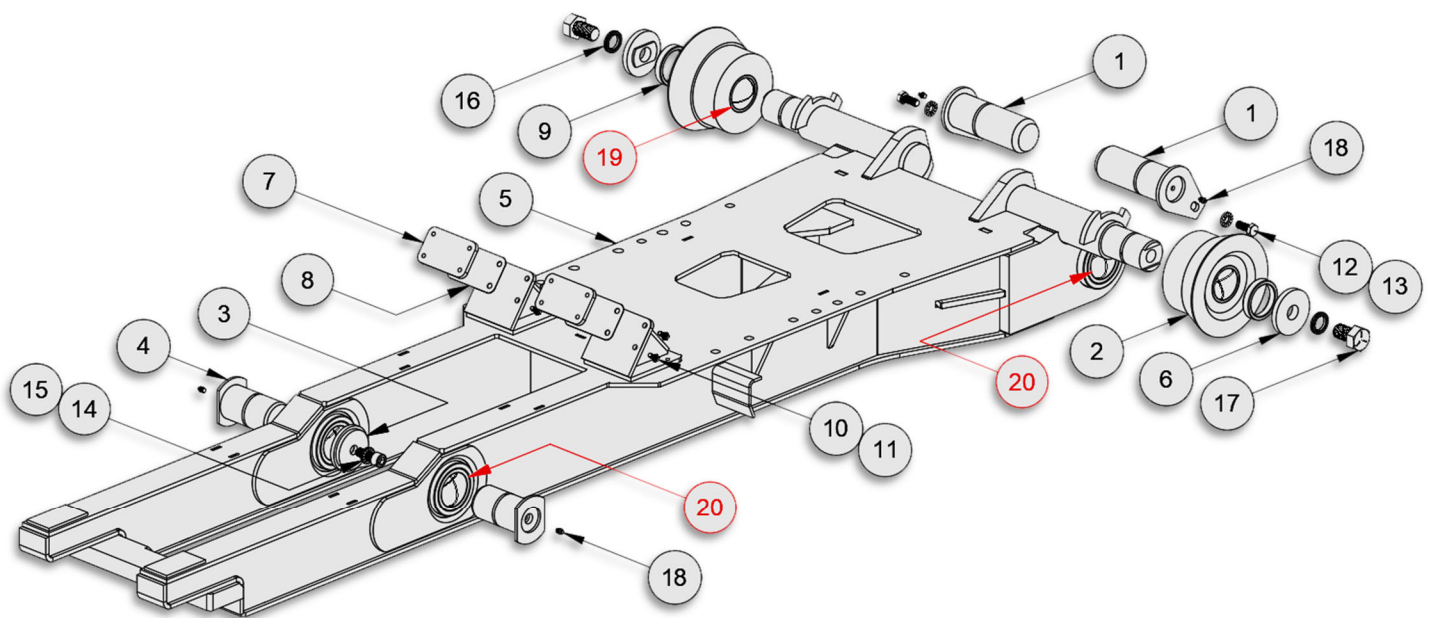

PIVOT JOINT SUB-ASSEMBLY

HEX HEAD CAP SCREW TORQUE SPECS	
BOLT SIZE	SAE GR 8 W/ LOCK WASHER (FT-LBS)
3/8	53
7/16	85
1/2	130
5/8	258
3/4	459
7/8	739
1	1108

Note: Apply Loctite 243 (Blue) to all bolts.

45H08 – OUTER TUBE SUB-ASSEMBLY					SL-520X	
ITEM	PART #	QTY	DESCRIPTION	WT-lb/ea.	WT-lb/all	
1	45H09	1	Outer Tube Weldment	744.90	744.90	
2	45H10	1	Pivot Lock Sub-Assembly	58.80	58.80	
3	45H32	6	Plug, Wear Pad Mnt	1.05	6.30	
4	77H04	2	Spacer, OT 3 x 5/16	0.30	0.60	
5	77H05	1	Shim 5-1/2 x 16GA x 5-1/2	0.48	0.48	
6	77H07	1	Pin, Jib/Cyl 1-3/4 x 6-11/32	5.91	5.91	
7	77H09	1	Cap, Jib/Cyl 3-1/2 x 2-3/16	2.63	2.63	
8	85H14	2	Pin Cap, 1/2 x 3-3/4	1.46	2.92	
9	86H08	2	Pin, OT/Cyl 1-3/4 x 2-7/8	4.39	8.78	
10	00P31	6	HHCS 1/2-13 UNC x 1-1/4	0.10	0.60	
11	00P55	1	Nut, Lock 5/8-11 UNC Gr8	0.08	0.08	
12	00P72	1	Nut, Lock 3/4-10 UNC Gr8	0.13	0.13	
13	00P89	1	HHCS 3/4-10 UNC x 1-3/4 Gr8	0.33	0.33	
14	01P16	12	FHCS 5/16-18 UNC x 1-1/4 Br	0.03	0.36	
15	01P30	6	Washer, Disc Lock 1/2 Pr	0.02	0.12	
16	01P36	1	HHCS 3/4-10 UNC x 9-1/2 Gr8	1.29	1.29	
17	01P43	1	HHCS 5/8-11 UNC x 7-12 Gr8	0.71	0.71	
18	02P08	8	FHCS 3/8-16 UNC x 3/4 ZP	0.03	0.24	
19	02P09	8	FHCS 3/8-16 UNC x 1-1/4 ZP	0.04	0.32	
20	23P16	1	Hyd Cyl, 4x2.75x52	332.71	332.71	
21	91P40	6	Wear Pad Ø2-1/4x7/8	0.11	0.66	
22	91P41	4	Wear Pad 2-3/4x1/2x5-1/2 THD	0.30	1.20	

JIB CYLINDER SERVICE PARTS (quantity per cylinder)				
23	23P43	1	Seal Kit	0.02
24	23P44	1	C'Bal Cart, 5000 PSI CBEG-LJN	0.50

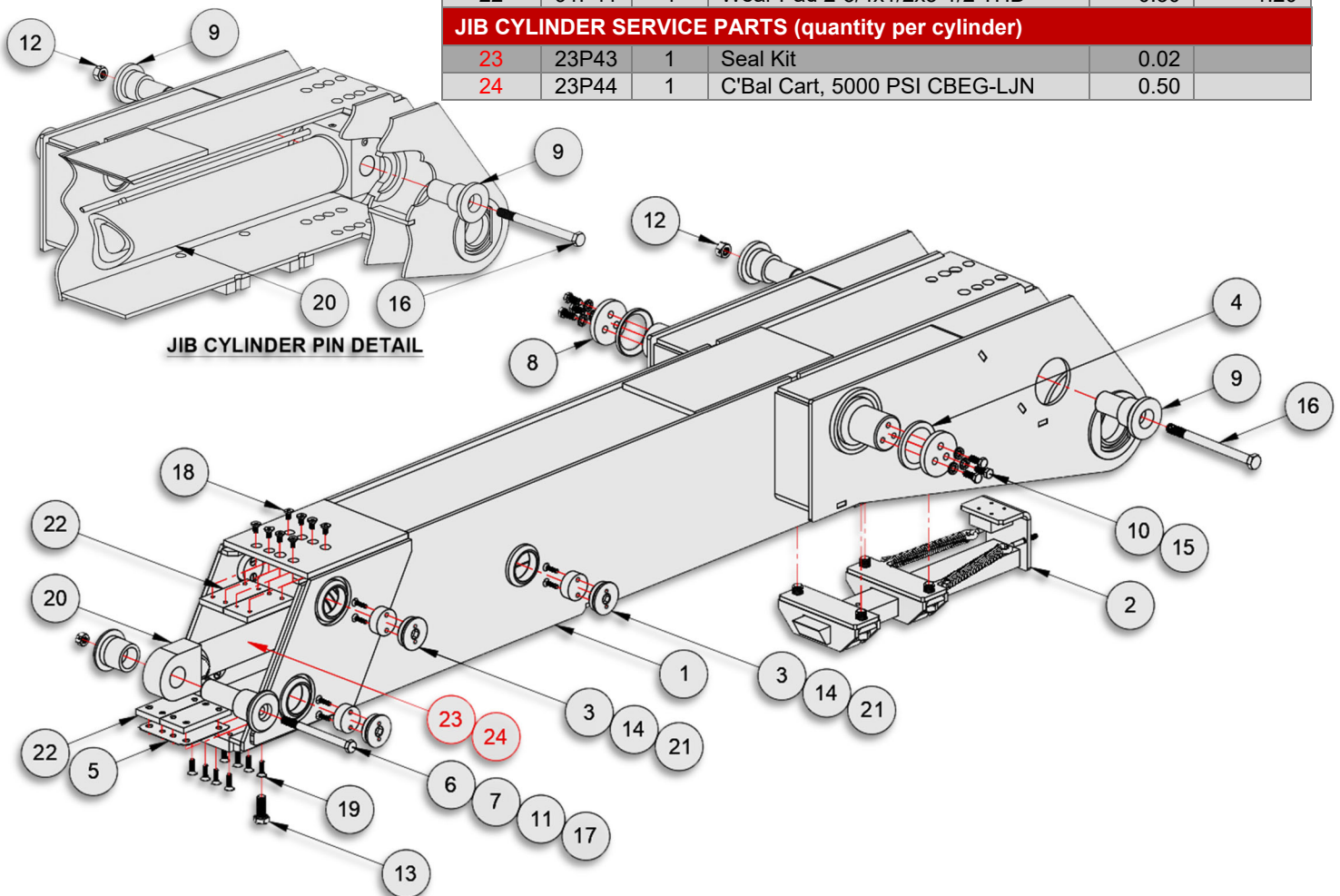

OUTER TUBE SUB-ASSEMBLY

HEX HEAD CAP SCREW TORQUE SPECS	
BOLT SIZE	SAE GR 8 W/ LOCK WASHER (FT-LBS)
3/8	53
7/16	85
1/2	130
5/8	258
3/4	459
7/8	739
1	1108

Note: Apply Loctite 243 (Blue) to all bolts.

SOCKET HEAD CAP SCREW TORQUE SPECS	
BOLT SIZE	SAE GR 8 W/ LOCK WASHER (FT-LBS)
3/8	62
7/16	103
1/2	151
5/8	291
3/4	516
7/8	831
1	1246

Note: Apply Loctite 243 (Blue) to all bolts.

45H10 – PIVOT LOCK SUB-ASSEMBLY					SL-520X	
ITEM	PART #	QTY	DESCRIPTION	WT-lb/ea.	WT-lb/all	
1	45H11	2	Pivot Lock Bkt, X-HD	6.21	12.42	
2	45H43	1	Slide, PL X-HD	5.80	5.80	
3	76H41	1	Spacer, Pivot Lock 3/8	2.55	2.55	
4	76H43	1	Pivot Lock Bar, X-HD	28.96	28.96	
5	76H44	1	Pronged Spacer, PL	2.72	2.72	
6	00P32	4	SHCS 3/8-16 UNC x 1-1/4 Gr8	0.05	0.20	
7	00P43	2	Nut, Nylock 3/8-16 UNC Gr8	0.02	0.04	
8	01P16	4	FHCS 5/16-18 UNC x 1-1/4 Br	0.03	0.12	
9	01P28	5	Washer, Disc Lock 3/8 Pr	0.01	0.05	
10	01P33	4	Washer, Disc Lock 7/8 Pr	0.07	0.28	
11	02P01	1	SHCS 3/8-16 UNC x 1/2 ZP	0.03	0.03	
12	02P12	4	HHCS 7/8-9 UNC x 2-1/4 Gr8	0.55	2.20	
13	23P13	2	Eyebolt 3/8-16 UNC x 3	0.19	0.38	
14	90P04	2	Spring, Ext 7/8 OD x 6 Lg	0.47	0.94	
15	91P48	1	Wear Pad, 2-1/2x1x2-1/2	0.24	0.24	

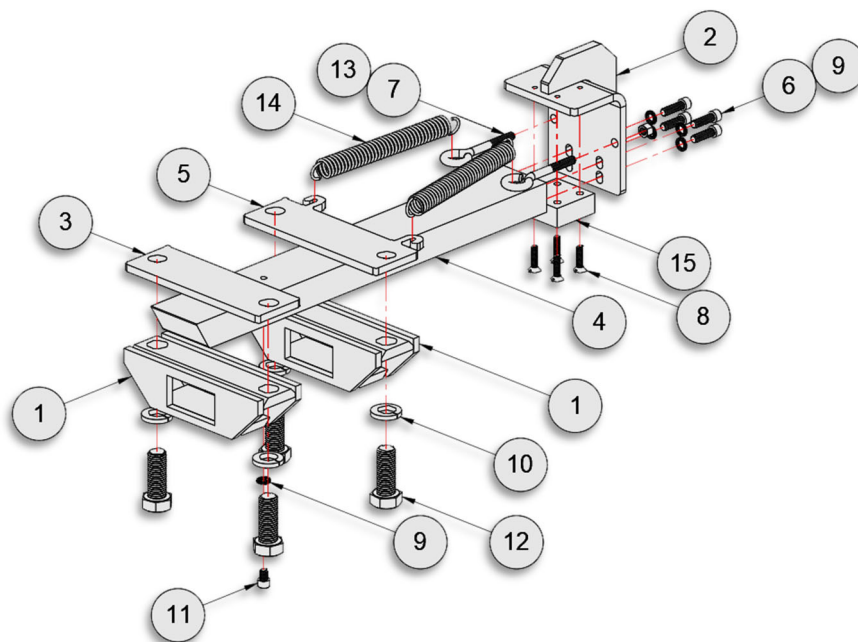

PIVOT LOCK SUB-ASSEMBLY

45H23 – BODY LOCK w/ SHELF ASSEMBLY**SL-520X**

ITEM	PART #	QTY	DESCRIPTION	WT-lb/ea.	WT-lb/all
1	45H24	1	Body Lock Wdmt, Shelf	224.19	224.19
2	00P61	8	FHCS 3/8-16 UNC x 3/4 Gr8	0.03	0.24
3	90P71	2	Wear Pad, 2-3/4x1/2x11-3/4	0.63	1.26

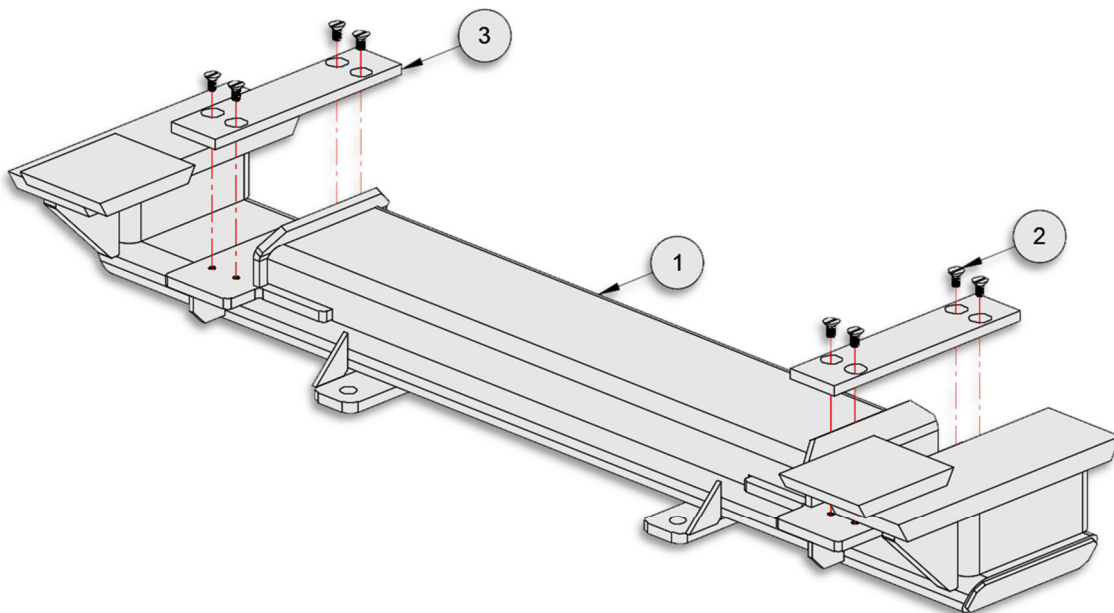
**BODY LOCK w/ SHELF ASSEMBLY**

HEX HEAD CAP SCREW TORQUE SPECS	
BOLT SIZE	SAE GR 8 W/ LOCK WASHER (FT-LBS)
3/8	53
7/16	85
1/2	130
5/8	258
3/4	459
7/8	739
1	1108

Note: Apply Loctite 243 (Blue) to all bolts.

45H14 – FIXED JIB SUB-ASSEMBLY					SL-520X	
ITEM	PART #	QTY	DESCRIPTION	WT-lb/ea.	WT-lb/all	
1	45H15	1	Fixed Jib Wdmt 62	733.57	733.57	
2	62H11	1	Cover, Jib 5-1/4x11GAx5-1/4	0.92	0.92	
3	77H05	1	Shim 5-1/2 x 16GA x 5-1/2	0.48	0.48	
4	80H35	4	Wear Pad, 2-3/4x1/2x5-1/2	0.28	1.12	
5	00755	2	Washer, Lock 3/8	0.03	0.06	
6	00P03	2	HHCS 3/8-16 UNC x 3/4 Gr8	0.04	0.08	
7	02P08	16	FHCS 3/8-16 UNC x 3/4 ZP	0.03	0.48	

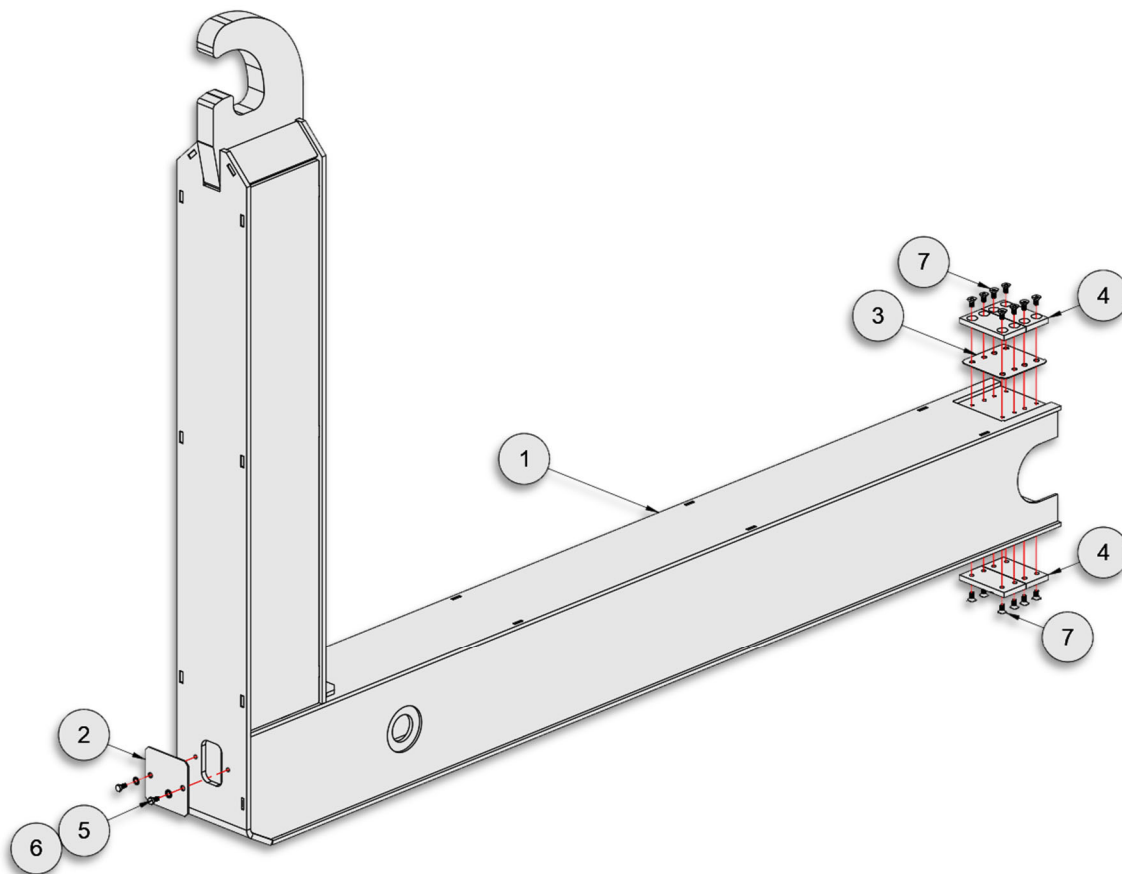

FIXED JIB SUB-ASSEMBLY

HEX HEAD CAP SCREW TORQUE SPECS	
BOLT SIZE	SAE GR 8 W/ LOCK WASHER (FT-LBS)
3/8	53
7/16	85
1/2	130
5/8	258
3/4	459
7/8	739
1	1108

Note: Apply Loctite 243 (Blue) to all bolts.

45H20 – HOIST INSTALLATION KIT					SL-520X	
ITEM	PART #	QTY	DESCRIPTION	WT-lb/ea.	WT-lb/all	
*	1	45H21	1	Parts & Op, SL-520X	1.00	1.00
*	2	45H22	1	Decal Assembly, SL-520X	0.38	0.38
	3	76H89	8	Mnt Bkt, 6x1/4x6-3/4	2.75	22.00
	4	77H19	6	Mnt Bkt, 2-1/8x3-3/4x11	4.01	24.06
	5	00785	74	Washer, Flat 5/8 HT	0.07	5.18
	6	00P55	74	Nut, Lock 5/8-11 UNC Gr8	0.13	9.62
	7	00P69	68	HHCS 5/8-11 UNC x 2 Gr8	0.33	22.44
	8	01P09	6	HHCS 5/8-11 UNC x 2-1/2 Gr8	0.30	1.80
	9	02P11	6	Washer, Flat 5/8 USS	0.09	0.54
	10	91P54	6	Spring, Urethane 1-1/2x3/4x1	0.05	0.30
*	11	91P79	1	All Model Tech Guide	0.50	0.50

* Item not shown.

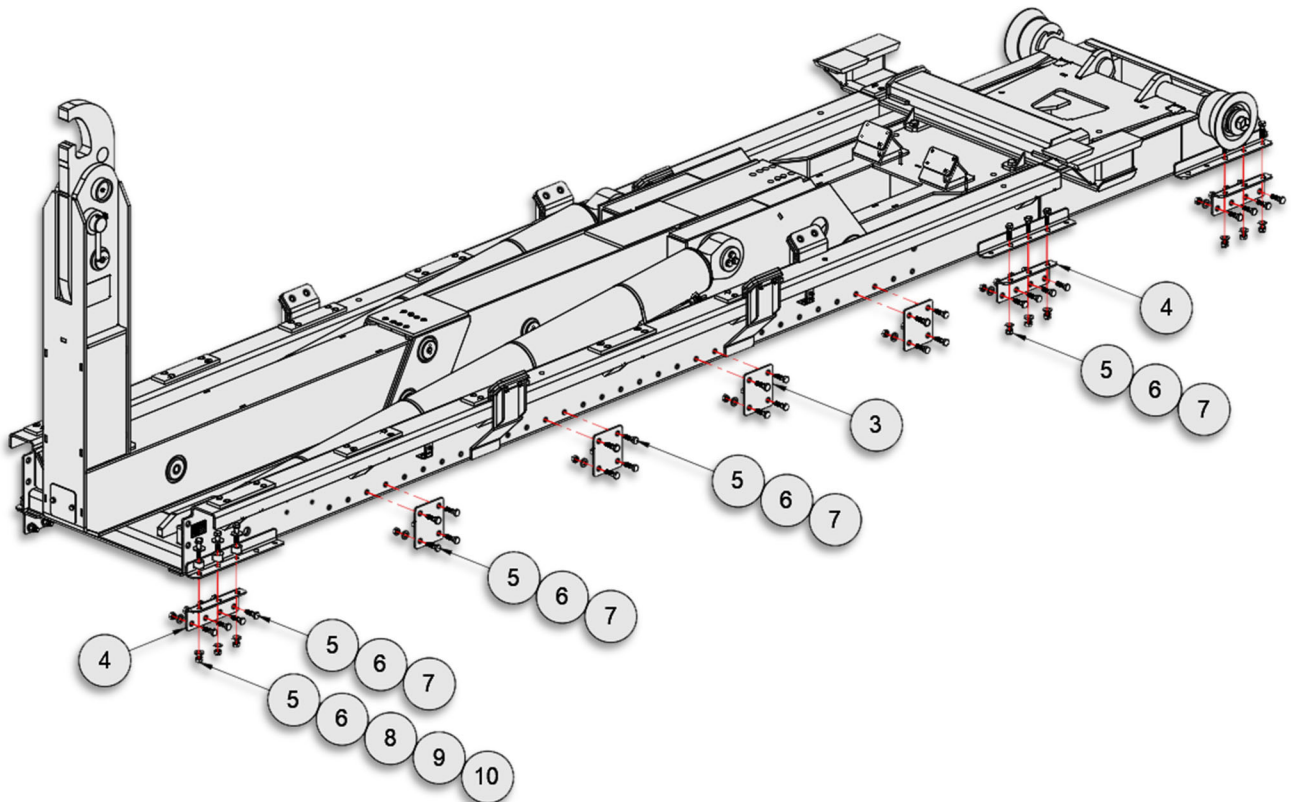

HOIST INSTALLATION KIT

91H77 – BASE CYLINDER CIRCUIT **SL-520X**

ITEM	PART #	QTY	DESCRIPTION	WT-lb/ea.	WT-lb/all
1	14P23	2	Adp Hyd 08FF/08FF/08FF BHD	0.30	0.60
2	14P24	2	Adp Hyd 08FF/08FF BH	0.30	0.60
3	14P25	6	Adp Hyd 08FF/08MF 90	0.30	1.20
4	14P26	6	Adp Hyd 08MF/08MF 90	0.30	1.80
5	14P27	4	Adp Hyd 08FF/08MF 45	0.30	1.20
6	14P28	2	Adp Hyd 08MF/08MB	0.30	0.60
7	14P29	1	Hose Assy 46 08-08FF/08FF	4.00	4.00
8	14P30	1	Hose Assy 42 08-08FF/08FF	3.80	3.80
9	14P31	3	Hose Assy 24 08-08FF/08FF	2.00	6.00
10	14P32	1	Hose Assy 149 08-08FF/08FF	12.00	12.00
11	14P33	1	Hose Assy 126 08-08FF/08FF	10.00	10.00
12	14P34	4	Adp Hyd 08FF Cap	0.30	1.20
13	14P41	2	Hyd Tube, 1-1/2 x 109	3.88	7.76
14	14P52	2	Adp Hyd 08FF Plug	0.03	0.06
15	23P04	1	Hyd Valve, 2-Way 08FB	5.20	5.20
16	90H17	2	Hose Clamp Assy, 1/2	0.17	0.34
17	90H74	1	Nylon Hose Sleeve	0.25	0.25

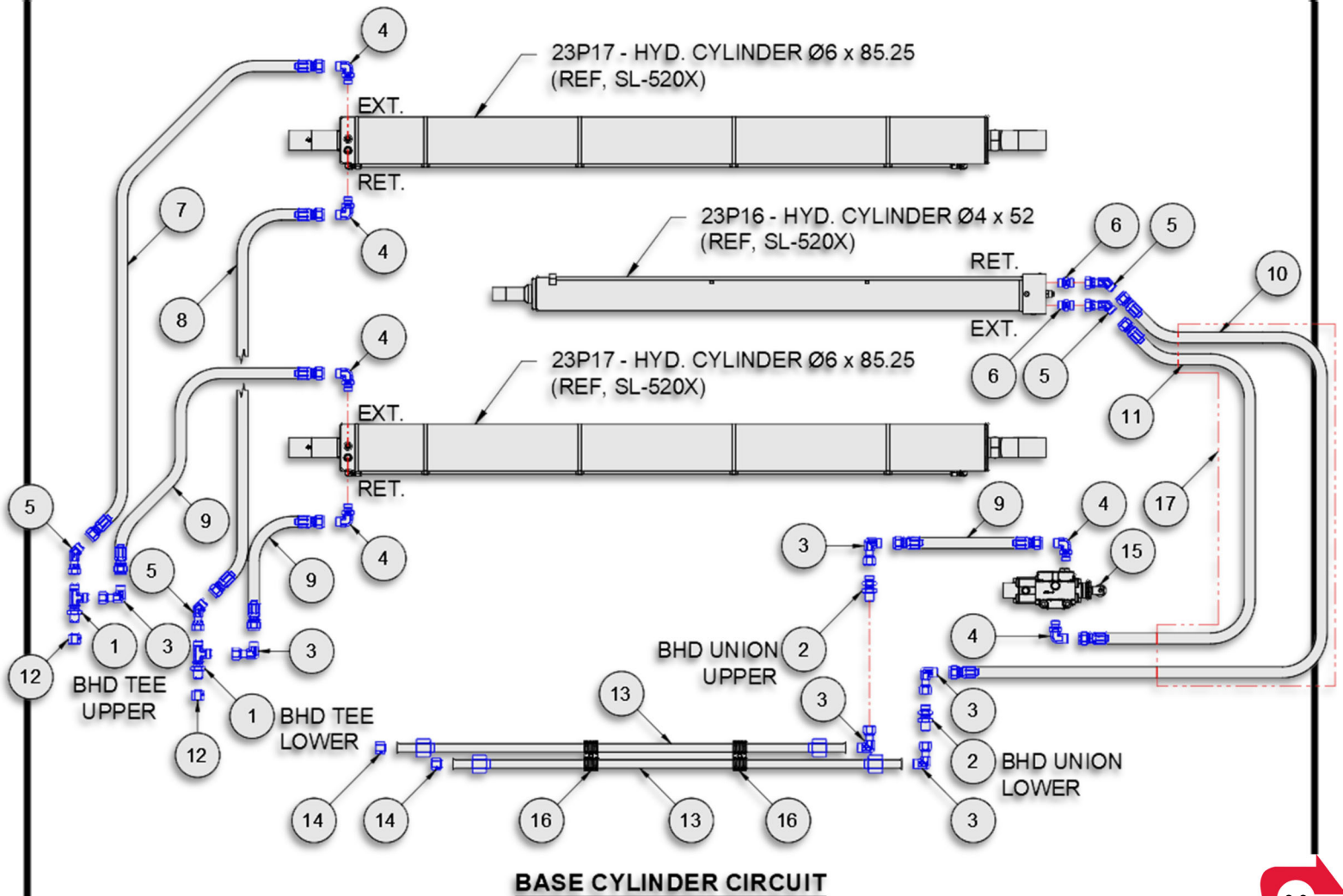

91H70 – TANK CIRCUIT				SL-520X	
ITEM	PART #	QTY	DESCRIPTION	WT-lb/ea.	WT-lb/all
1	00784	4	Washer, Flat 1/2 HT	0.01	0.04
2	00P15	4	HHCS 1/2-13 UNC x 1-3/4 Gr8	0.20	0.80
3	00P35	4	Nut, Lock 1/2-13 UNC GrC	0.05	0.20
4	10P34	1	Adp Hyd 12MJ/16MP	0.30	0.30
5	10P36	1	Adp Hyd 12MJ/12MB 90	0.30	0.30
6	11P94	1	Adp Hyd 12MJ/12FJ 45	0.30	0.30
7	14P25	2	Adp Hyd 08FF/08MF 90	0.40	0.80
8	14P37	2	Adp Hyd 08MF/08MF	0.17	0.34
9	14P39	1	Hose Assy 33 08-08FF/08FF	3.12	3.12
10	14P40	1	Hose Assy 29 08-08FF/08FF	2.82	2.82
11	14P68	4	Adp Hyd 08MF/10MB	0.30	1.20
12	14P69	2	Hose Assy 19.5 08-08FF/08FF90	3.00	6.00
13	14P73	1	Hose Assy 36 12-12FJ/12FJ	3.00	3.00
14	21P16	1	Hyd Strainer, 50 GPM	2.50	2.50
15	23P29	1	Hyd Tank, 25 Gallon 10um	71.00	71.00
TANK SERVICE PARTS					
16	20P96	1	Sight Gauge, Hyd Tank		
17	23P31	1	Breather Cap Assy, Hyd Tank		
18	23P33	1	Hyd Filter Assy, 25 GPM		
19	23P34	1	Hyd Filter Element (23P29)		

Note: Tank consists of tank weldment, sight gauge, filler/breather cap, filter assembly, magnetic drain plug and port plugs.

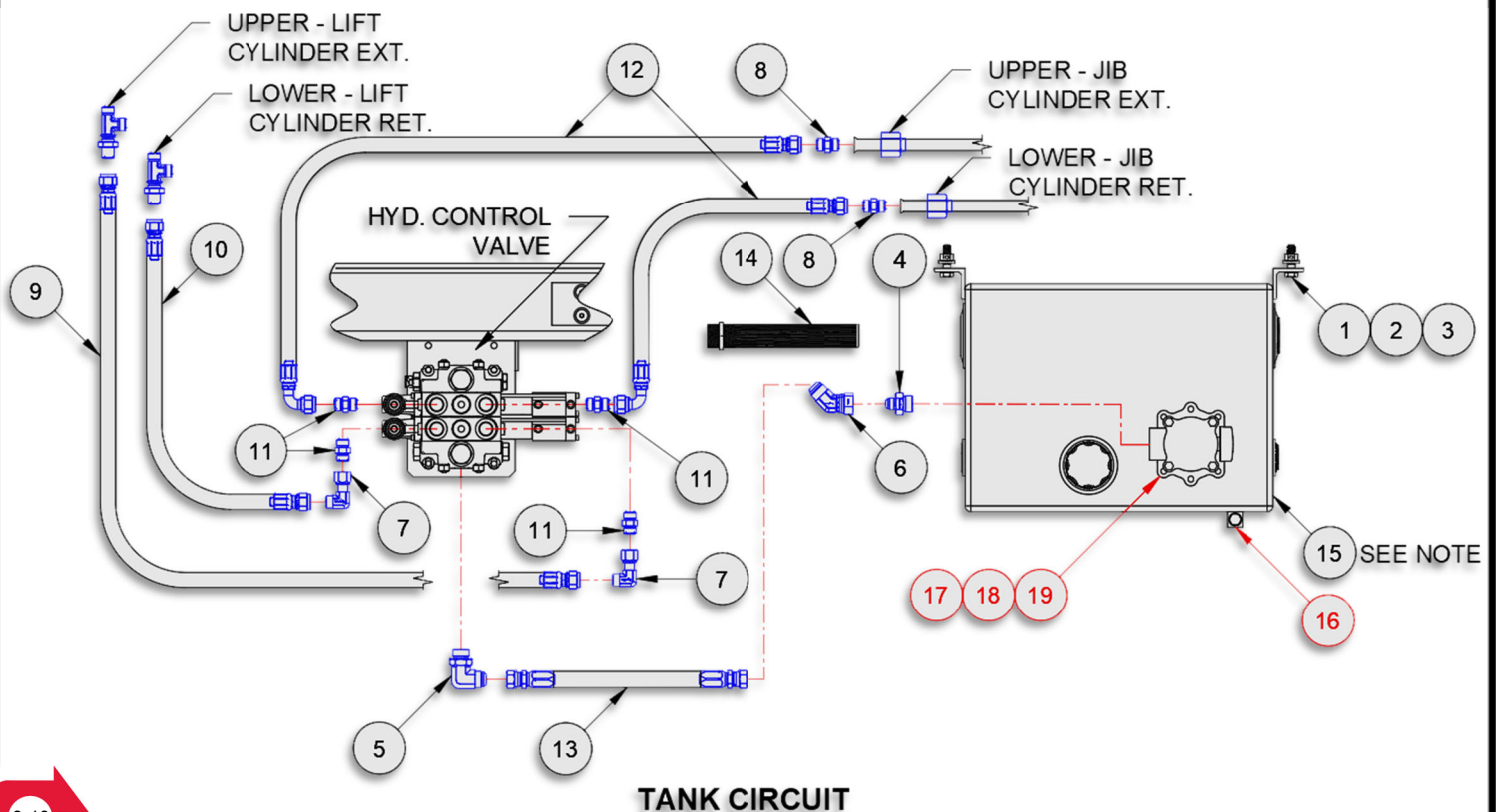

TANK CIRCUIT

91H71 – PUMP CIRCUIT				SL-520X	
ITEM	PART #	QTY	DESCRIPTION	WT-lb/ea.	WT-lb/all
1	11P71	1	Hose 1-1/2 x 120 LP	9.60	9.60
2	11P77	2	Clamp, T-Bolt Ø2	0.20	0.40
3	11P95	1	Adp Hyd 24HB/24MP	0.40	0.40
4	12P48	1	Adp Hyd 32MP/24FP	0.60	0.60
5	14P42	1	Adp Hyd 12MF/10MB	0.40	0.40
6	14P43	1	Adp Hyd 12MF/12MB 45	0.77	0.77
7	14P67	1	Ball Valve 32FP/32FP	5.00	5.00

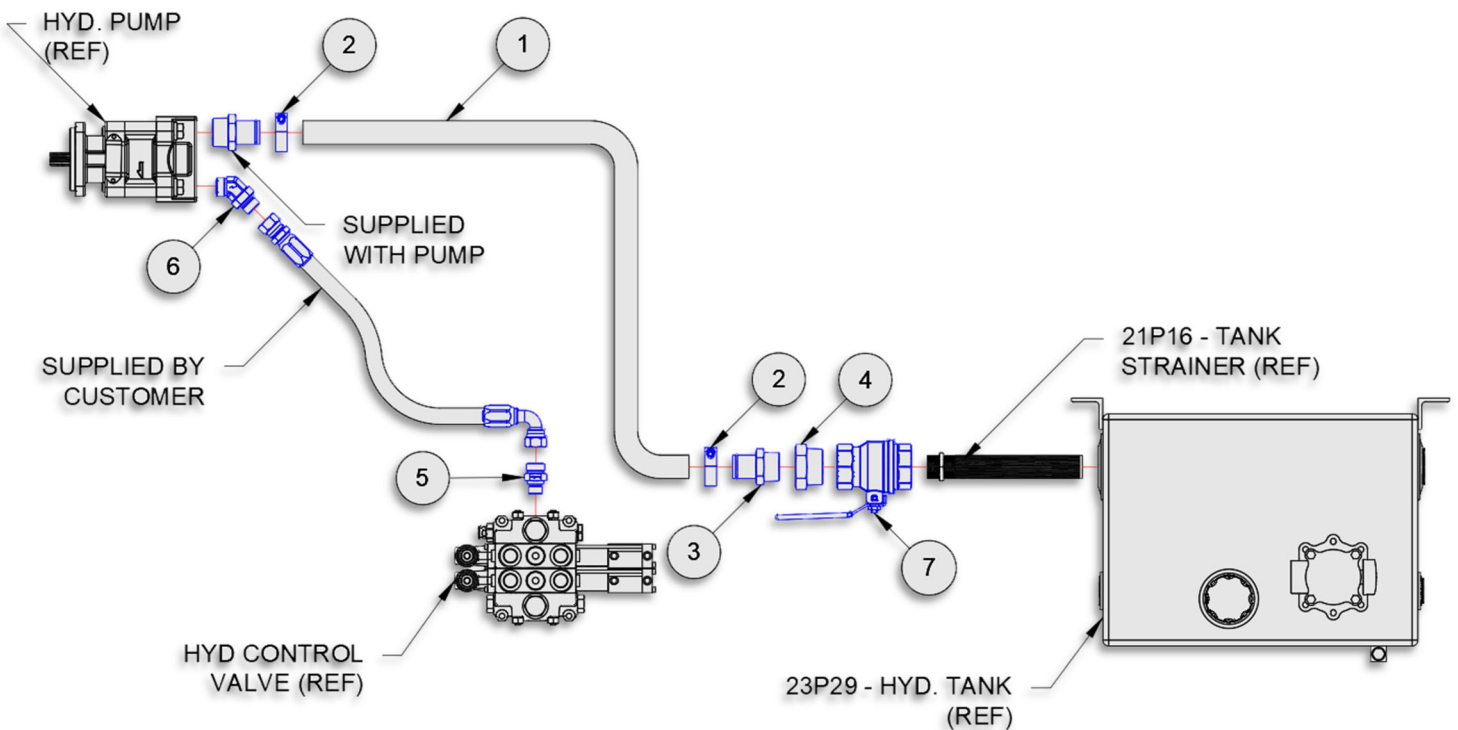

PUMP CIRCUIT

HEX HEAD CAP SCREW TORQUE SPECS	
BOLT SIZE	SAE GR 8 W/ LOCK WASHER (FT-LBS)
5/16	30
3/8	53
7/16	85
1/2	130
5/8	258
3/4	459
7/8	739
1	1108

Note: Apply Loctite 243 (Blue) to all bolts.

91H72 – AIR CONTROLS, 2-SECTION					SL-520X	
ITEM	PART #	QTY	DESCRIPTION	WT-lb/ea.	WT-lb/all	
1	45H34	1	Valve Mnt Bkt, X-HD	15.12	15.12	
2	51H27	1	Air Ctrl Console, 2-Sect	4.20	4.20	
3	00752	4	Washer, Lock 5/16	0.03	0.12	
4	00P14	4	Nut, Hex 3/8-16 UNC Gr8	0.02	0.08	
5	00P19	4	HHCS 5/16-18 UNC x 2-3/4 Gr8	0.02	0.08	
6	00P20	4	Nut, Hex 5/16-18 UNC Gr8	0.01	0.04	
7	00P44	4	HHCS 3/8-16 UNC x 1-1/2 Gr8	0.07	0.28	
8	01P28	4	Washer, Disc Lock 3/8 Pr	0.01	0.04	
9	12P94	1	Air Line Kit	1.40	1.40	
10	14P45	1	Adp Hyd 12MB/04FB	0.34	0.34	
11	20P72	1	Control Handle, 2-Sect Air	1.60	1.60	
12	20P74	1	Air Pressure Protection Valve	0.60	0.60	
13	23P21	1	Hyd Valve, 2-Sect 4650 D4	46.00	46.00	
14	23P38	2	Manual Control Handle, 5.5 in	0.50	1.00	
15	23P39	1	Hyd Gauge, 5000 PSI	1.00	1.00	

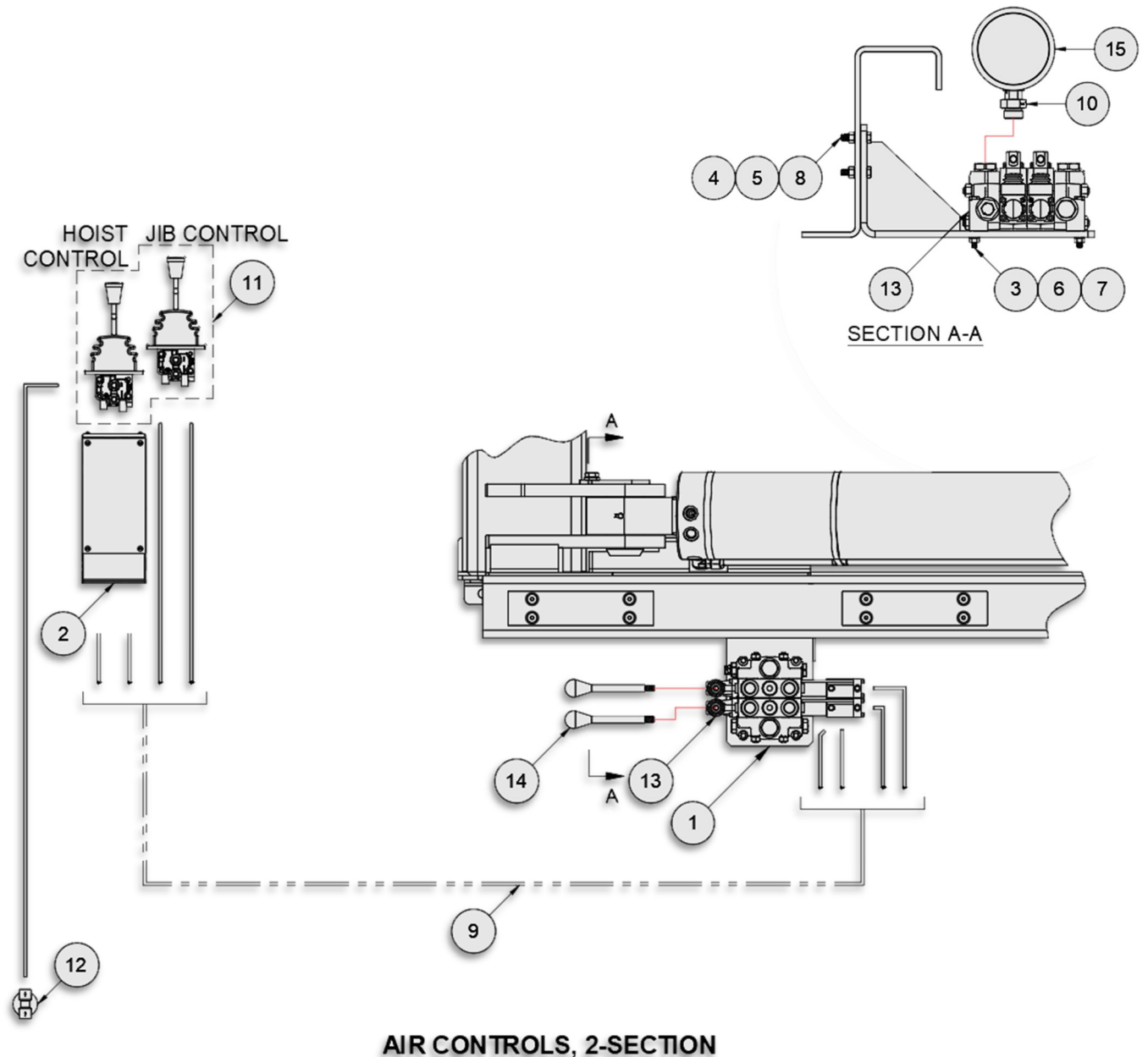

AIR CONTROLS, 2-SECTION

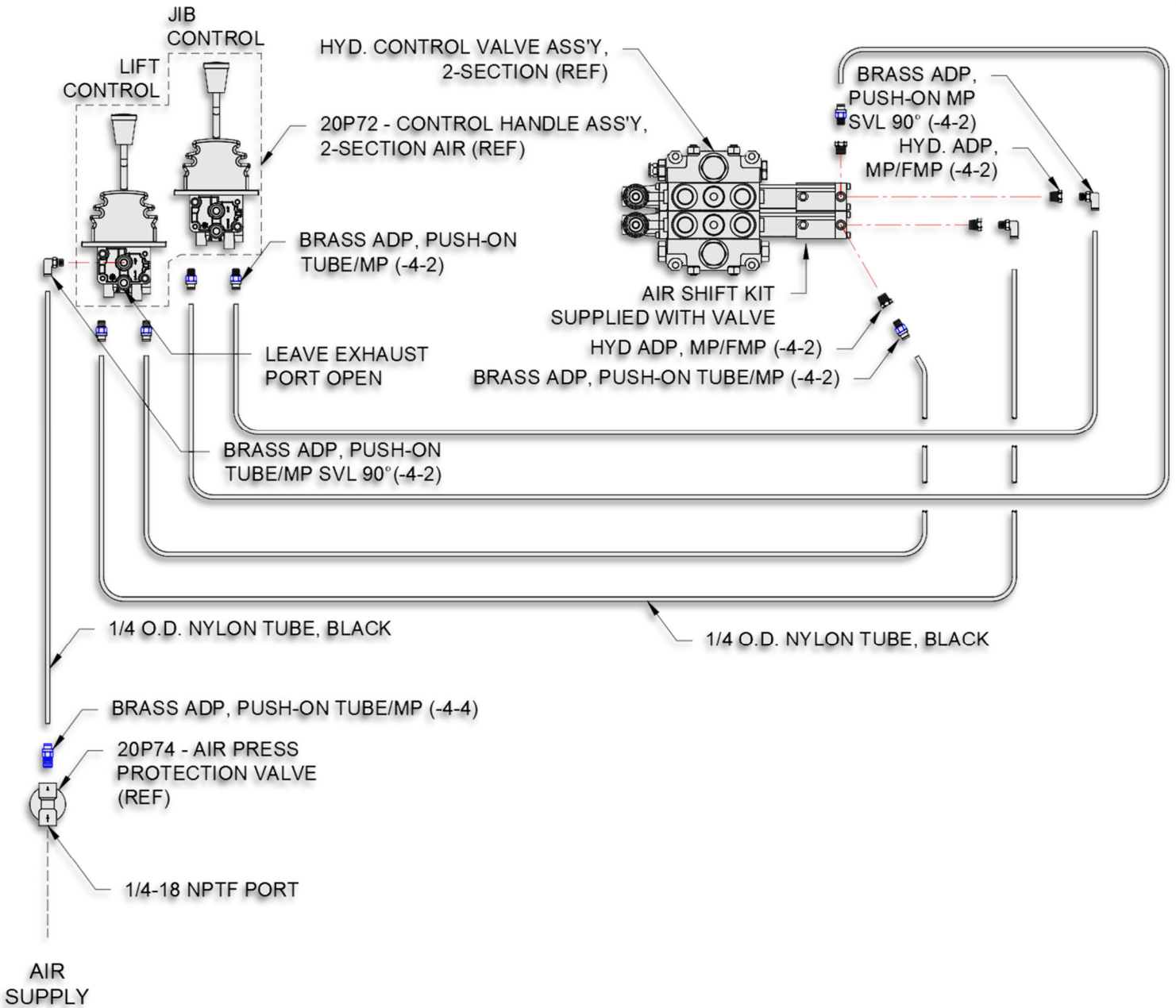

AIR CIRCUIT PLUMBING DIAGRAM, 2-SECTION

NOTE:

1. FITTING AND TUBING SHOWN ARE PART OF THE 12P94 AIR LINE KIT WHICH CONTAINS FITTINGS FOR MULTIPLE HOIST/PLUMBING CONFIGURATIONS. NOT ALL FITTINGS MAY BE UTILIZED.

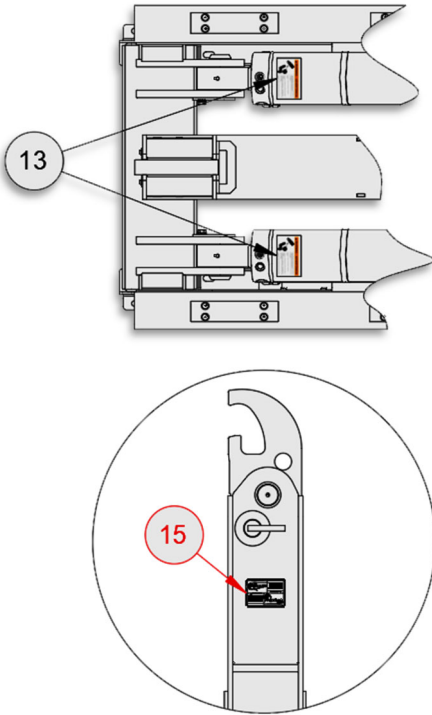

45H22 – DECAL ASSEMBLY SL-520X

ITEM	PART #	QTY	DESCRIPTION	WT-lb/ea.	WT-lb/all
1	90P07	2	Decal, Op & Service Manual	0.01	0.02
2	90P08	2	Decal, Hoist/Body	0.02	0.04
3	90P09	1	Decal, Hyd Oil	0.02	0.02
4	90P10	1	Decal, Hyd Oil Flammable	0.03	0.03
5	90P11	2	Decal, Hoist Falling	0.03	0.06
6	90P12	1	Decal, Lever Control	0.02	0.02
7	90P13	1	Decal, Safety Instructions	0.03	0.03
8	90P14	2	Decal, SwapLoader	0.03	0.06
9	90P18	1	Decal, Relief Valve	0.03	0.03
10	90P78	1	Decal, High-Pressure Fluids	0.01	0.01
11	91P06	2	Decal, Lubrication Points	0.01	0.02
12	91P47	4	Decal, SL-520X	0.02	0.08
13	91P52	3	Decal, Counterbalance Valve	0.01	0.03
14	91P66	1	Decal, Outside Controls	0.01	0.01

ADJUSTABLE JIB OPTION ONLY

15	90P94	2	Decal, Adj Jib Op 54/62	0.01	
----	-------	---	-------------------------	------	--

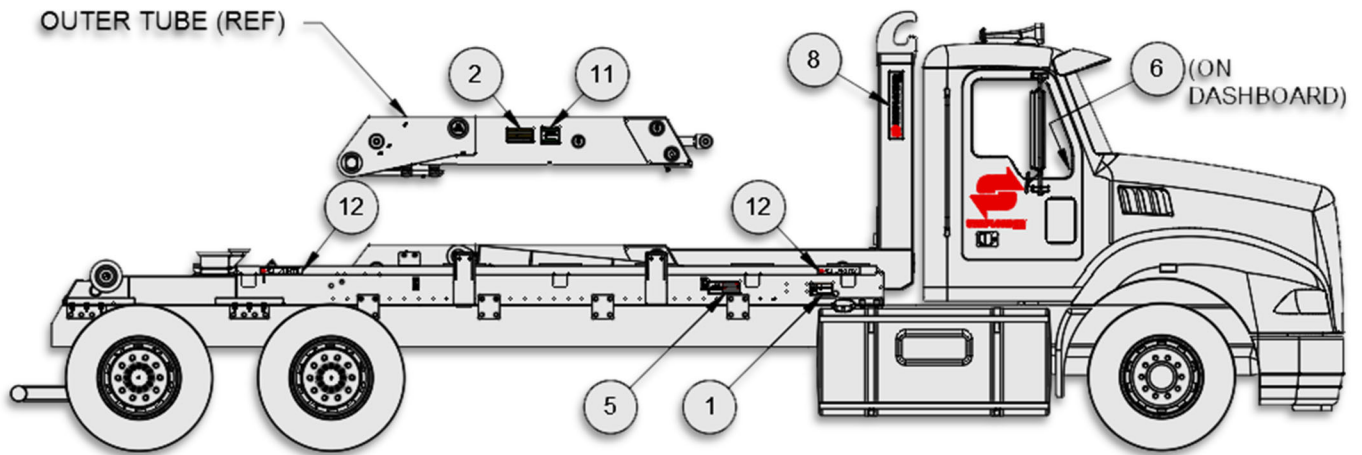

RIGHT SIDE

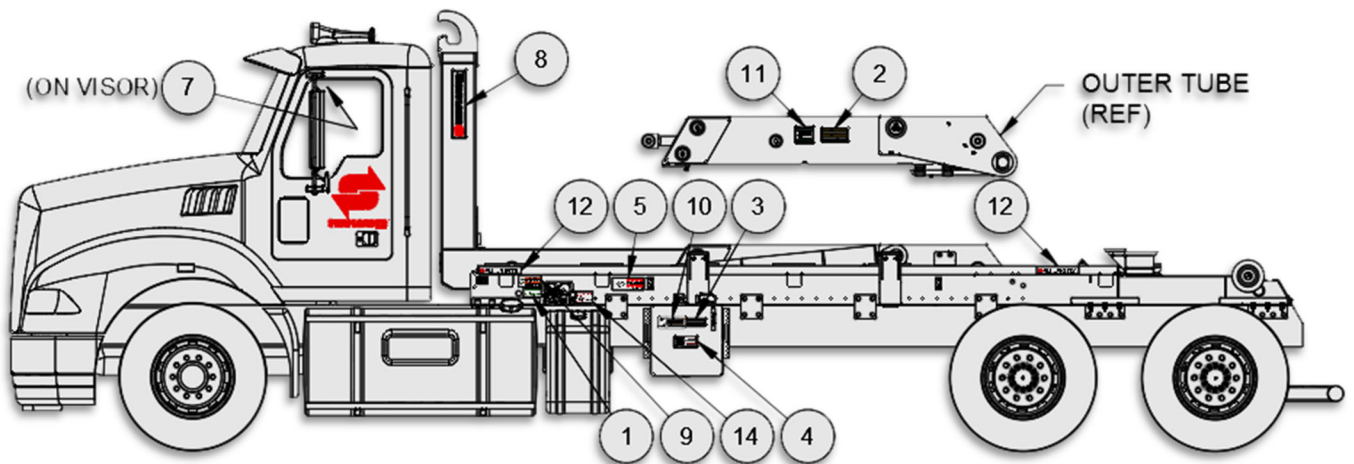

LEFT SIDE

OPTIONS

This Page Intentionally Left Blank

HEX HEAD CAP SCREW TORQUE SPECS	
BOLT SIZE	SAE GR 8 W/ LOCK WASHER (FT-LBS)
3/8	53
7/16	85
1/2	130
5/8	258
3/4	459
7/8	739
1	1108

Note: Apply Loctite 243 (Blue) to all bolts.

45H12 – ADJUSTABLE JIB SUB-ASSEMBLY					SL-520X	
ITEM	PART #	QTY	DESCRIPTION	WT-lb/ea.	WT-lb/all	
1	43H10	1	Pin, Hook Pvt 2-3/4 x 5-3/8	12.38	12.38	
2	45H13	1	Adj Jib Wdmt 54/62, 520X	688.46	688.46	
3	45H32	2	Plug, Wear Pad Mnt	1.04	2.08	
4	45H38	1	Pin, Hook Lock 2-1/4 x 7-5/8	10.49	10.49	
5	62H11	1	Cover, Jib 5-1/4x11GAx5-1/4	0.90	0.90	
6	77H05	1	Shim, WP 5-1/2 x 16GA x 5-1/2	0.48	0.48	
7	80H35	4	Wear Pad, 2-3/4x1/2x5-1/2	0.30	1.20	
8	86H95	1	Hook, Adj Jib 54/62	146.50	146.50	
9	86H98	1	Lock Tube, Jib 3-1/2ODx1-1/2	1.20	1.20	
10	00755	2	Washer, Lock 3/8	0.03	0.06	
11	53586	1	Safety Snap Pin, 3/8 x 2-1/2	0.14	0.14	
12	00P03	2	HHCS 3/8-16 UNC x 3/4 Gr8	0.04	0.08	
13	00P34	1	Nut, Lock 3/8-16 UNC GrC	0.02	0.02	
14	00P99	1	HHCS 3/8-16 UNC x 4 Gr8	0.22	0.22	
15	01P16	4	FHCS 5/16-18 UNC x 1-1/4 Br	0.03	0.12	
16	02P08	16	FHCS 3/8-16 UNC x 3/4 ZP	0.03	0.48	
17	23P40	1	Spring Plunger, 1/2-13 SS	0.05	0.05	
18	90P03	1	Grease Zerk, 1/8-27 NPT Str	0.01	0.01	
19	90P94	2	Decal, Adj Jib Op 54/62	0.01	0.02	
20	91P42	2	Wear Pad, 2-1/4 Dia x 1-3/8	0.20	0.40	

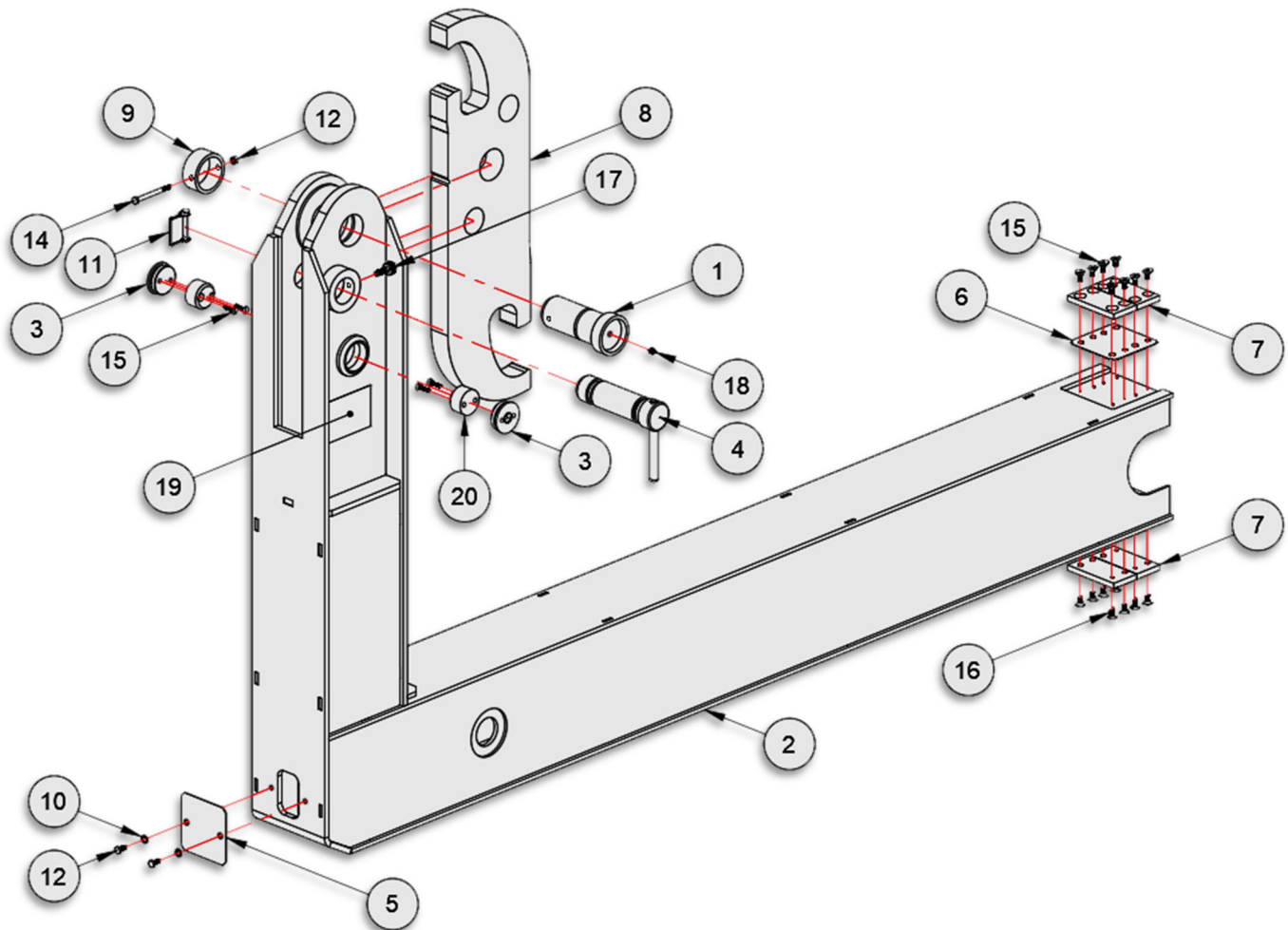

ADJUSTABLE JIB SUB-ASSEMBLY

HEX HEAD CAP SCREW TORQUE SPECS	
BOLT SIZE	SAE GR 8 W/ LOCK WASHER (FT-LBS)
3/8	53
7/16	85
1/2	130
5/8	258
3/4	459
7/8	739
1	1108

Note: Apply Loctite 243 (Blue) to all bolts.

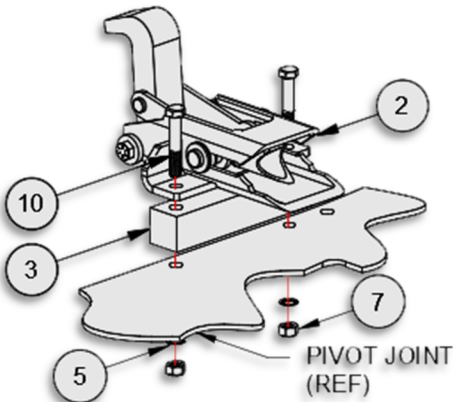

HYD BODY LOCK MOUNTING DETAIL

91H79- CYLINDER CIRCUIT, UL 520X STD					SL-520X	
ITEM	PART #	QTY	DESCRIPTION	WT-lb/ea.	WT-lb/all	
1	27H22	1	Valve Mnt Bkt, Solenoid 100S	1.33	1.33	
2	44H79	1	U-Lock Assy, HD	116.96	116.96	
3	89H42	2	Shim, BL Mnt 2	17.54	35.08	
4	90H74	1	Nylon Hose Sleeve x 60"	0.25	0.25	
5	00769	4	Washer, Lock 3/4	0.08	0.32	
6	00770	8	Washer, Flat 1/4	0.01	0.08	
7	00P17	4	Nut, Hex 3/4-10 UNC Gr8	0.19	0.76	
8	00P47	2	HHCS 1/4-20 UNC x 2-1/4 Gr8	0.01	0.02	
9	00P51	4	Nut, Lock 1/4-20 UNC Gr8	0.01	0.04	
10	01P38	4	HHCS 3/4-10 UNC x 4 Gr8	0.68	2.72	
11	01P56	2	HHCS 1/4-20 UNC x 1 Gr8	0.02	0.04	
12	10P43	2	Adp Hyd 08MJ/08MJ BHD	0.30	0.60	
13	10P44	2	Adp Hyd 08MJ/08FJ 90	0.30	0.60	
14	13P14	2	Adp Hyd 08FJ Cap	0.32	0.64	
15	13P77	2	Adp Hyd 06MJ/06MB .062 Rstr.	0.30	0.60	
16	13P87	2	Adp Hyd 08FJ/06MJ	0.30	0.60	
17	14P28	1	Adp Hyd 08MF/08MB	0.20	0.20	
18	14P38	1	Hose Assy 21 08-08FF/08FF	2.21	2.21	
19	14P46	2	Hose Assy 123 06-06FJ/06FJ	4.75	9.50	
20	14P47	2	Adp Hyd 12MB/08FB	0.21	0.42	
21	14P48	1	Adp Hyd 08MB/08FF	0.21	0.21	
22	23P36	1	Solenoid Valve, U-Lock HP	2.85	2.85	
23	91P50	2	Decal, Pinch Point	0.01	0.02	
24	91P51	3	Decal, U-Lock Engagement	0.01	0.03	

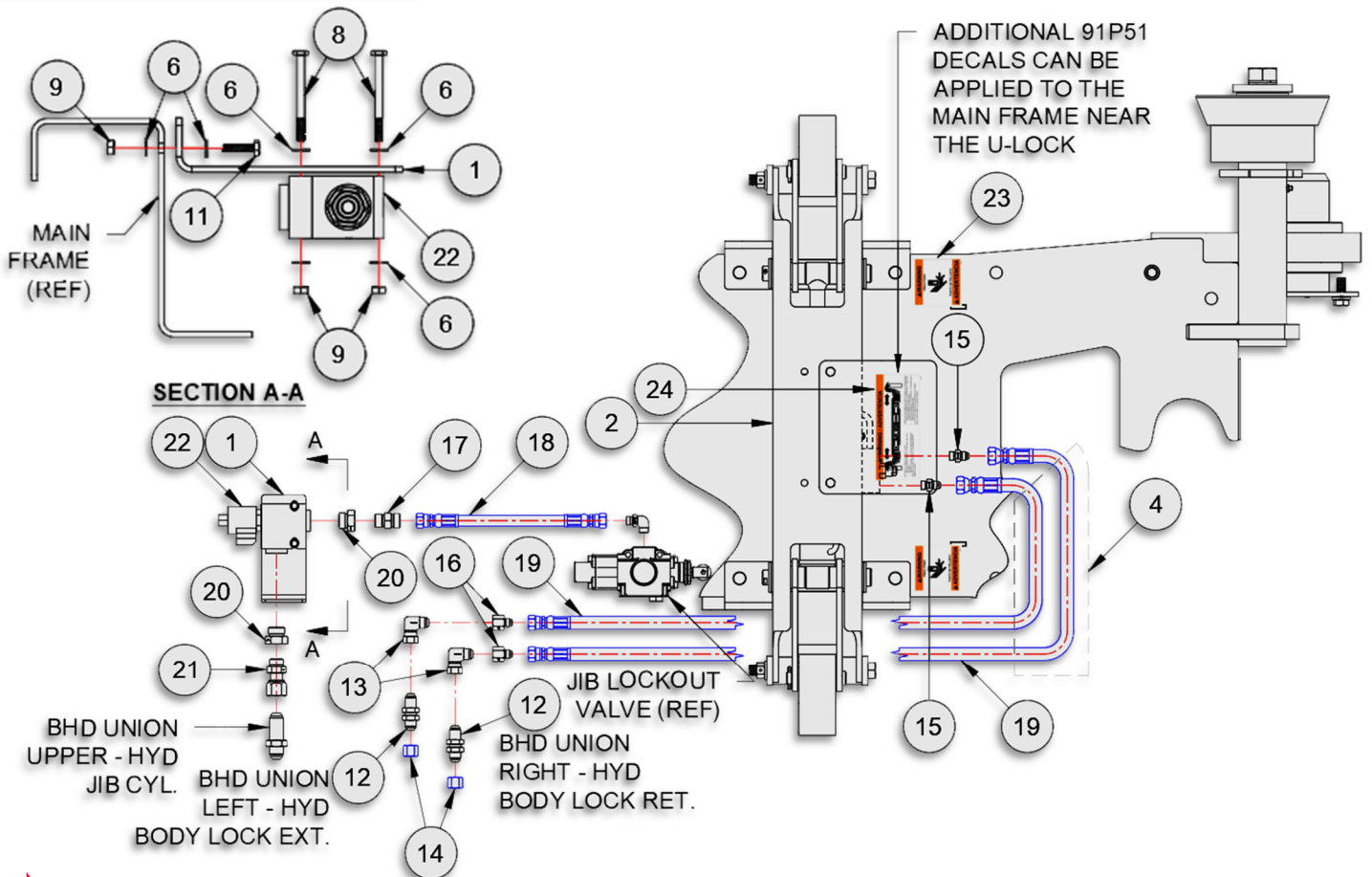

CYL CIRCUIT, UL X-HD STD

HEX HEAD CAP SCREW TORQUE SPECS	
BOLT SIZE	SAE GR 8 W/ LOCK WASHER (FT-LBS)
3/8	53
7/16	85
1/2	130
5/8	258
3/4	459
7/8	739
1	1108

Note: Apply Loctite 243 (Blue) to all bolts.

44H79 – U-LOCK ASSEMBLY				SL-520X	
ITEM	PART #	QTY	DESCRIPTION	WT-lb/ea.	WT-lb/all
1	26H98	2	Prong, U-Lock HD	14.2	28.4
2	27H26	1	Cover Plate, Hyd Lock	1.9	1.9
3	44H80	1	U-Lock Wdmt, HD	48.62	48.62
4	44H81	4	Linkage Wdmt, U-Lock HD	1.89	7.56
5	00837	2	Pin, Cotter 3/16 Dia x 2	0.02	0.04
6	00P14	2	Nut, Hex 3/8-16 UNC Gr8	0.02	0.04
7	00P62	2	HHCS 3/8-16 UNC x 1 Gr8	0.05	0.1
8	00P67	2	Nut, Lock 1-8 UNC Gr8	0.29	0.58
9	01P28	2	Washer, Disc Lock 3/8 Pr	0.01	0.02
10	01P87	10	Washer, Flat 1 ZP	0.1	1
11	01P89	4	Washer, Flat 1 Nylon	0.01	0.04
12	01P91	6	Washer, Flat 3/4 SS	0.02	0.12
13	01P92	2	Pin, Slt'd Spg 5/32 x 1-1/2 ZP	0.01	0.02
14	01P95	2	Pin, Clevis 3/4 x 3-1/2	0.52	1.04
15	01P96	2	Pin, Clevis 1 x 6-11/16	1.65	3.3
16	02P37	2	HHCS 1-8 UNC x 8-1/2 Gr8	0.27	0.54
17	22P93	1	Hyd Cyl 2x1x6, HD	14.14	14.14
U-LOCK CYLINDER SERVICE PARTS					
18	22P78	1	C'Bal Cart, 5000 PSI CBCG-LJN	0.50	

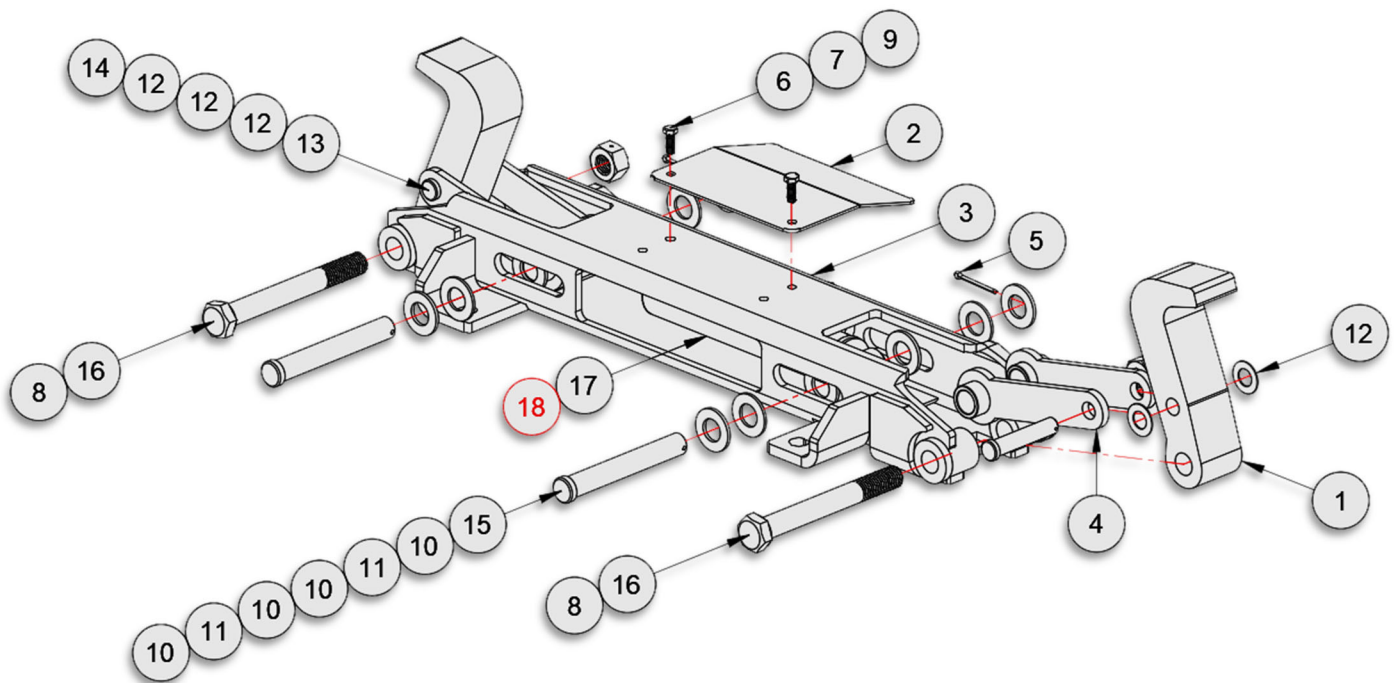

U-LOCK ASSEMBLY

HEX HEAD CAP SCREW TORQUE SPECS	
BOLT SIZE	SAE GR 8 W/ LOCK WASHER (FT-LBS)
3/8	53
7/16	85
1/2	130
5/8	258
3/4	459
7/8	739
1	1108

Note: Apply Loctite 243 (Blue) to all bolts.

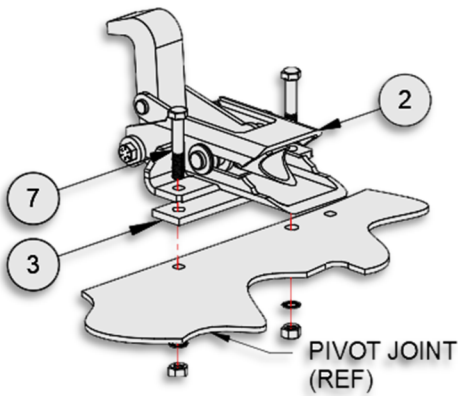

HYD BODY LOCK MOUNTING DETAIL

91H80- CYLINDER CIRCUIT, OL 520X STD				SL-520X	
ITEM	PART #	QTY	DESCRIPTION	WT-lb/ea.	WT-lb/all
1	27H22	1	Valve Mnt Bkt, Solenoid 100S	1.33	1.33
2	45H39	1	O-Lock Assy, X-HD	177.47	177.47
3	89H06	2	Shim, BL Mnt 1/2	4.52	9.04
4	90H74	1	Nylon Hose Sleeve x 60"	0.25	0.25
5	00770	8	Washer, Flat 1/4	0.01	0.08
6	00P51	4	Nut, Lock 1/4-20 UNC Gr8	0.01	0.04
7	01P70	4	HHCS 3/4-10 UNC x 2-1/4 Gr8	0.39	1.56
8	01P41	2	HHCS 1/4-20 UNC x 2-3/4 Gr8	0.04	0.08
9	01P56	2	HHCS 1/4-20 UNC x 1 Gr8	0.02	0.04
10	10P43	2	Adp Hyd 08MJ/08MJ BHD	0.3	0.6
11	10P44	2	Adp Hyd 08MJ/08FJ 90	0.3	0.6
12	13P14	2	Adp Hyd 08FJ Cap	0.32	0.64
13	13P77	2	Adp Hyd 06MJ/06MB .062 Rstr.	0.3	0.6
14	13P87	2	Adp Hyd 08FJ/06MJ	0.3	0.6
15	14P28	1	Adp Hyd 08MF/08MB	0.2	0.2
16	14P38	1	Hose Assy 21 08-08FF/08FF	2.21	2.21
17	14P46	2	Hose Assy 123 06-06FJ/06FJ	4.75	9.5
18	14P47	2	Adp Hyd 12MB/08FB	0.21	0.42
19	14P48	1	Adp Hyd 08MB/08FF	0.21	0.21
20	23P36	1	Solenoid Valve, U-Lock HP	2.85	2.85

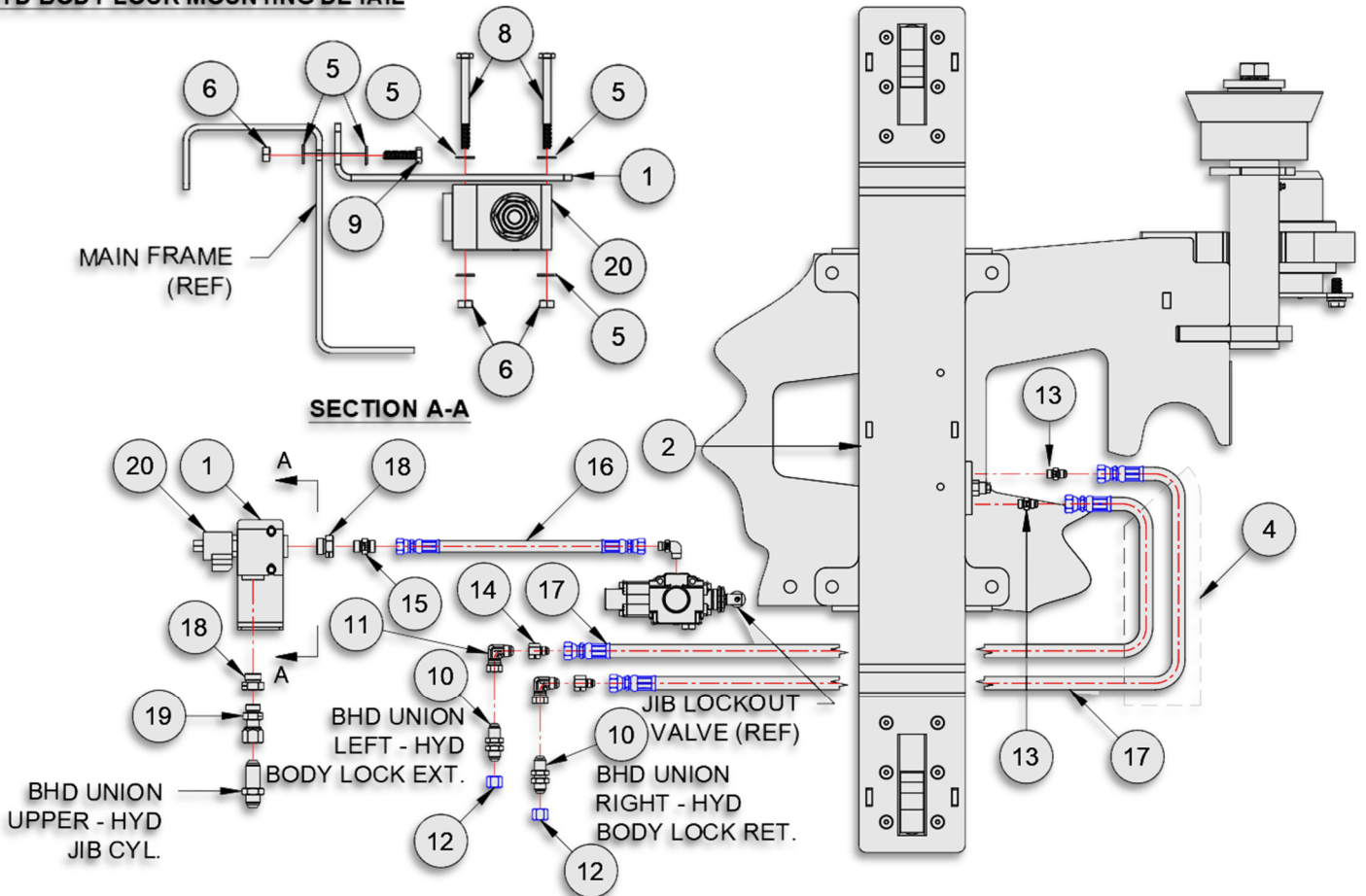

CYL CIRCUIT, OL X-HD STD

HEX HEAD CAP SCREW TORQUE SPECS	
BOLT SIZE	SAE GR 8 W/ LOCK WASHER (FT-LBS)
3/8	53
7/16	85
1/2	130
5/8	258
3/4	459
7/8	739
1	1108

Note: Apply Loctite 243 (Blue) to all bolts.

45H39 – O-LOCK ASSEMBLY				SL-418X/518X	
ITEM	PART #	QTY	DESCRIPTION	WT-lb/ea.	WT-lb/all
1	27H26	1	Cover Plate, Hyd Lock	1.9	1.9
2	45H40	1	Outside Lock Wdmt, X-HD	115.85	115.85
3	45H41	2	Slide Wdmt, Outside Lock	16.32	32.64
4	77H18	2	Prong STD, Outside Lock	3.8	7.6
5	00837	2	Pin, Cotter 3/16 Dia x 2	0.02	0.04
6	00P14	2	Nut, Hex 3/8-16 UNC Gr8	0.02	0.04
7	00P62	2	HHCS 3/8-16 UNC x 1 Gr8	0.05	0.1
8	01P17	4	HHCS 5/8-11 UNC x 2-1/4 Gr8	0.3	1.2
9	01P28	2	Washer, Disc Lock 3/8 Pr	0.01	0.02
10	01P31	4	Washer, Disc Lock 5/8 Pr	0.03	0.12
11	02P08	24	FHCS 3/8-16 UNC x 3/4 ZP	0.03	0.72
12	02P10	2	Pin, Clevis 1 x 4-1/2	1.1	2.2
13	23P37	1	Hyd Cyl 1.5x1x6.5, 4750 PSI	13.9	13.9
14	91P53	8	Wear Pad, 1-3/4x15/32x18-1/2	0.3	2.4
O-LOCK CYLINDER SERVICE PARTS					
15	22P78	1	C'Bal Cart, 5000 PSI CBCG-LJN	0.50	

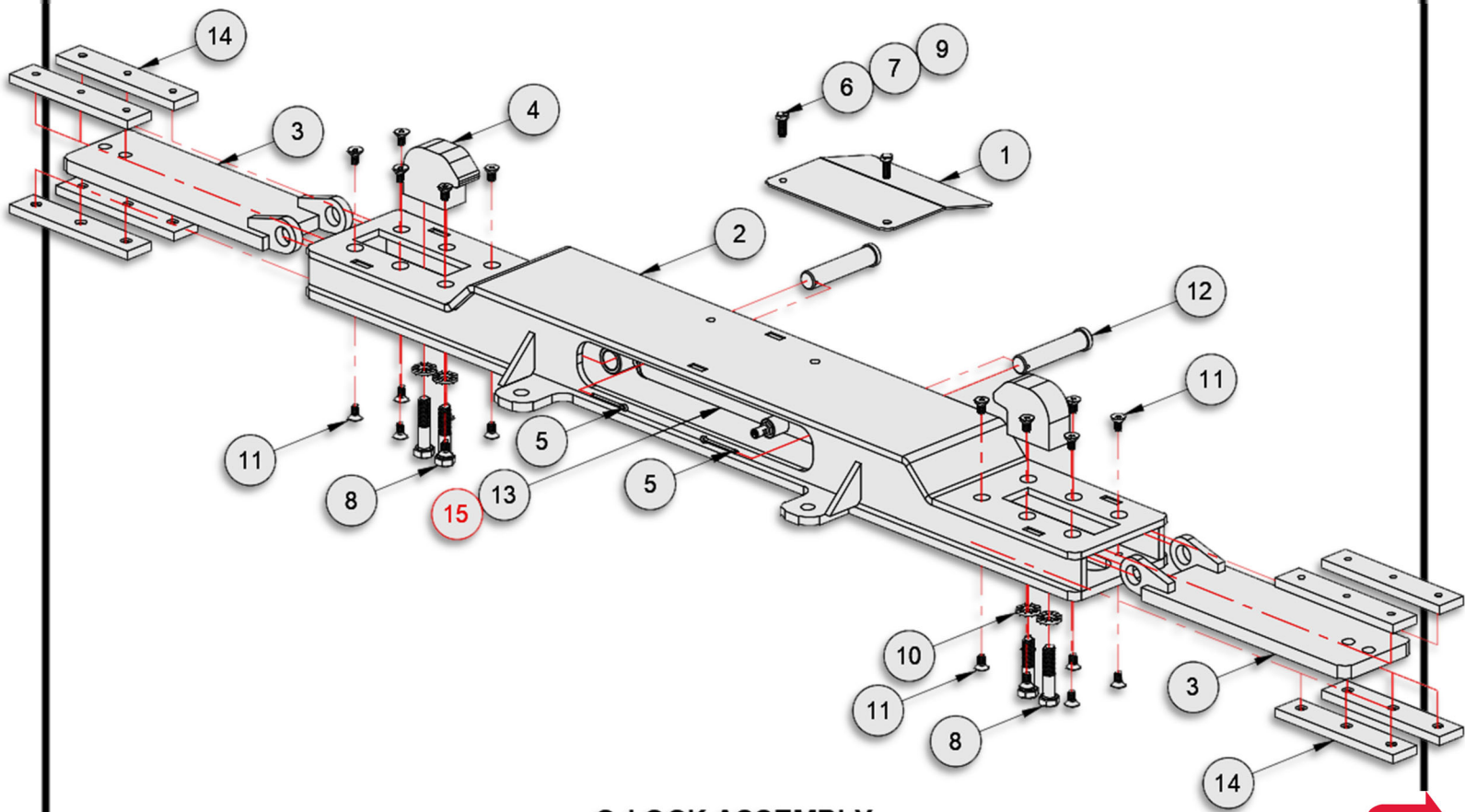

O-LOCK ASSEMBLY

91H73 – AIR CONTROLS, 3-SECTION					SL-520X	
ITEM	PART #	QTY	DESCRIPTION	WT-lb/ea.	WT-lb/all	
1	45H34	1	Valve Mnt Bkt, X-HD	15.12	15.12	
2	51H37	1	Air Ctrl Console, 3-Sect	4.90	4.90	
3	00752	4	Washer, Lock 5/16	0.03	0.12	
4	00P14	4	Nut, Hex 3/8-16 UNC Gr8	0.02	0.08	
5	00P19	4	HHCS 5/16-18 UNC x 2-3/4 Gr8	0.02	0.08	
6	00P20	4	Nut, Hex 5/16-18 UNC Gr8	0.01	0.04	
7	00P44	4	HHCS 3/8-16 UNC x 1-1/2 Gr8	0.07	0.28	
8	01P28	4	Washer, Disc Lock 3/8 Pr	0.01	0.04	
9	12P94	1	Air Line Kit	1.40	1.40	
10	14P45	1	Adp Hyd 12MB/04FB	0.34	0.34	
11	20P73	1	Control Handle, 3-Sect Air	2.40	2.40	
12	20P74	1	Air Pressure Protection Valve	0.60	0.60	
13	23P25	1	Hyd Valve, 3-Sect HP Air WR	58.00	58.00	
14	23P38	3	Manual Control Handle, 5.5"	0.50	1.50	
15	23P39	1	Hyd Gauge, 5000 PSI	1.00	1.00	

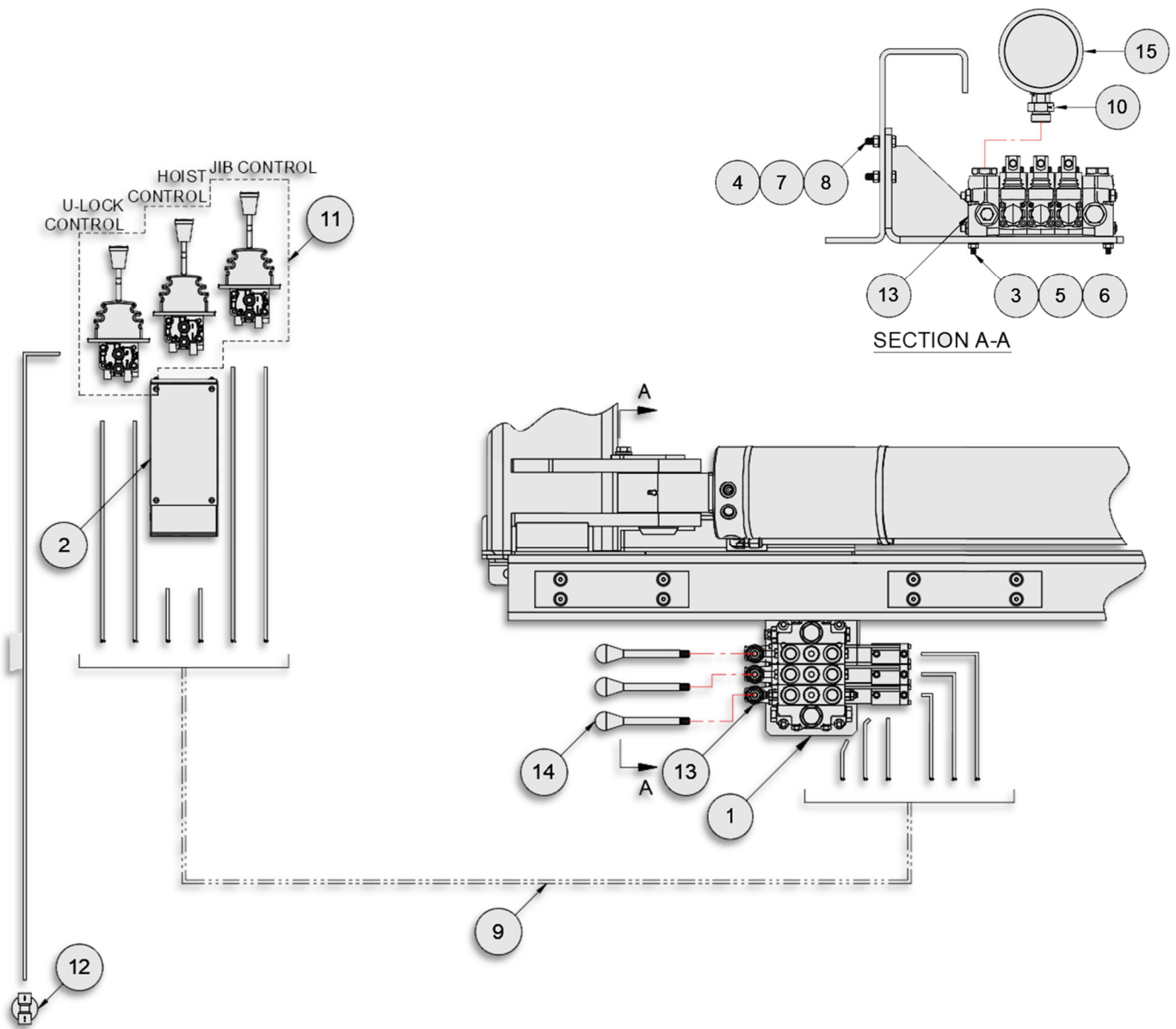

AIR CONTROLS, 3-SECTION

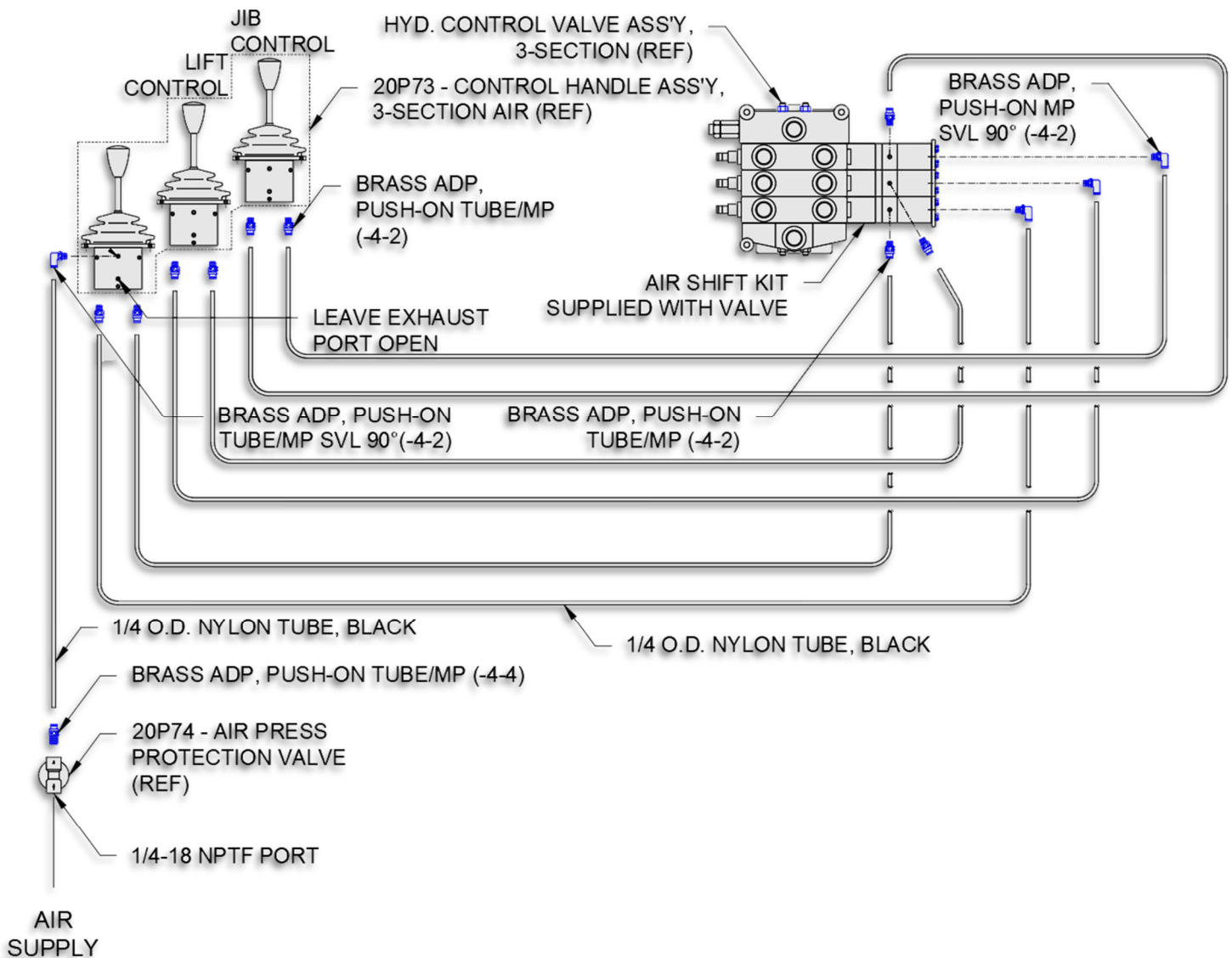

AIR CIRCUIT PLUMBING DIAGRAM, 3-SECTION

NOTE:

1. FITTING AND TUBING SHOWN ARE PART OF THE 12P94 AIR LINE KIT WHICH CONTAINS FITTINGS FOR MULTIPLE HOIST/PLUMBING CONFIGURATIONS. NOT ALL FITTINGS MAY BE UTILIZED.
2. THE 20P71 AIR SHIFT KITS ARE TO BE INSTALLED ON THE HYD. CONTROL VALVE BY THE HOIST INSTALLER. PREFERENCE INSTALLTION INSTRUCTIONS INCLUDED WITH THE AIR SHIFT KIT.

TANK SERVICE PARTS		
ITEM	PART #	DESCRIPTION
25	20P96	Sight Gauge, Hyd Tank
26	23P31	Breather Cap Assy, Hyd Tank
27	23P33	Hyd Filter Assy, 25 GPM
28	23P34	Hyd Filter Element (23P29)

NOTE:
 TANK CONSISTS OF TANK WELDMENT, SIGHT GAUGE, FILLER/BREATHER CAP, FILTER ASSEMBLY, MAGNETIC DRAIN PLUG AND PORT PLUGS.

91H78 – TANK CIRCUIT, 3-SECTION					SL-520X	
ITEM	PART #	QTY	DESCRIPTION	WT-lb/ea.	WT-lb/all	
1	91H76	2	Twin Clamp Assy, 1/2-7/8	0.29	0.58	
2	00784	4	Washer, Flat 1/2 HT	0.01	0.04	
3	00P15	4	HHCS 1/2-13 UNC x 1-3/4 Gr8	0.20	0.80	
4	00P35	4	Nut, Lock 1/2-13 UNC GrC	0.05	0.20	
5	10P34	1	Adp Hyd 12MJ/16MP	0.30	0.30	
6	10P36	1	Adp Hyd 12MJ/12MB 90	0.30	0.30	
7	10P44	2	Adp Hyd 08MJ/08FJ 90	0.30	0.60	
8	10P45	1	Adp Hyd 08MJ/10MB 90	0.30	0.30	
9	10P46	1	Adp Hyd 08MJ/10MB 90 LL	0.30	0.30	
10	11P94	1	Adp Hyd 12MJ/12FJ 45	0.30	0.30	
11	13P80	2	Adp Hyd 08MJ/08FJ	0.30	0.60	
12	13P87	4	Adp Hyd 08FJ/06MJ	0.30	1.20	
13	14P25	1	Adp Hyd 08FF/08MF 90	0.40	0.40	
14	14P37	2	Adp Hyd 08MF/08MF	0.17	0.34	
15	14P39	1	Hose Assy 33 08-08FF/08FF	3.12	3.12	
16	14P40	1	Hose Assy 29 08-08FF/08FF	2.82	2.82	
17	14P46	2	Hose Assy 123 06-06FJ/06FJ	4.75	9.50	
18	14P68	3	Adp Hyd 08MF/10MB	0.30	0.90	
19	14P69	2	Hose Assy 19.5 08-08FF/08FF90	3.00	6.00	
20	14P70	1	Adp Hyd 10MF/10MB 90 LL	0.30	0.30	
21	14P71	1	Adp Hyd 10FF/08MF	0.30	0.30	
22	14P73	1	Hose Assy 36 12-12FJ/12FJ	3.00	3.00	
23	21P16	1	Hyd Strainer, 50 GPM	2.50	2.50	
24	23P29	1	Hyd Tank, 25 Gallon 10um	71.00	71.00	

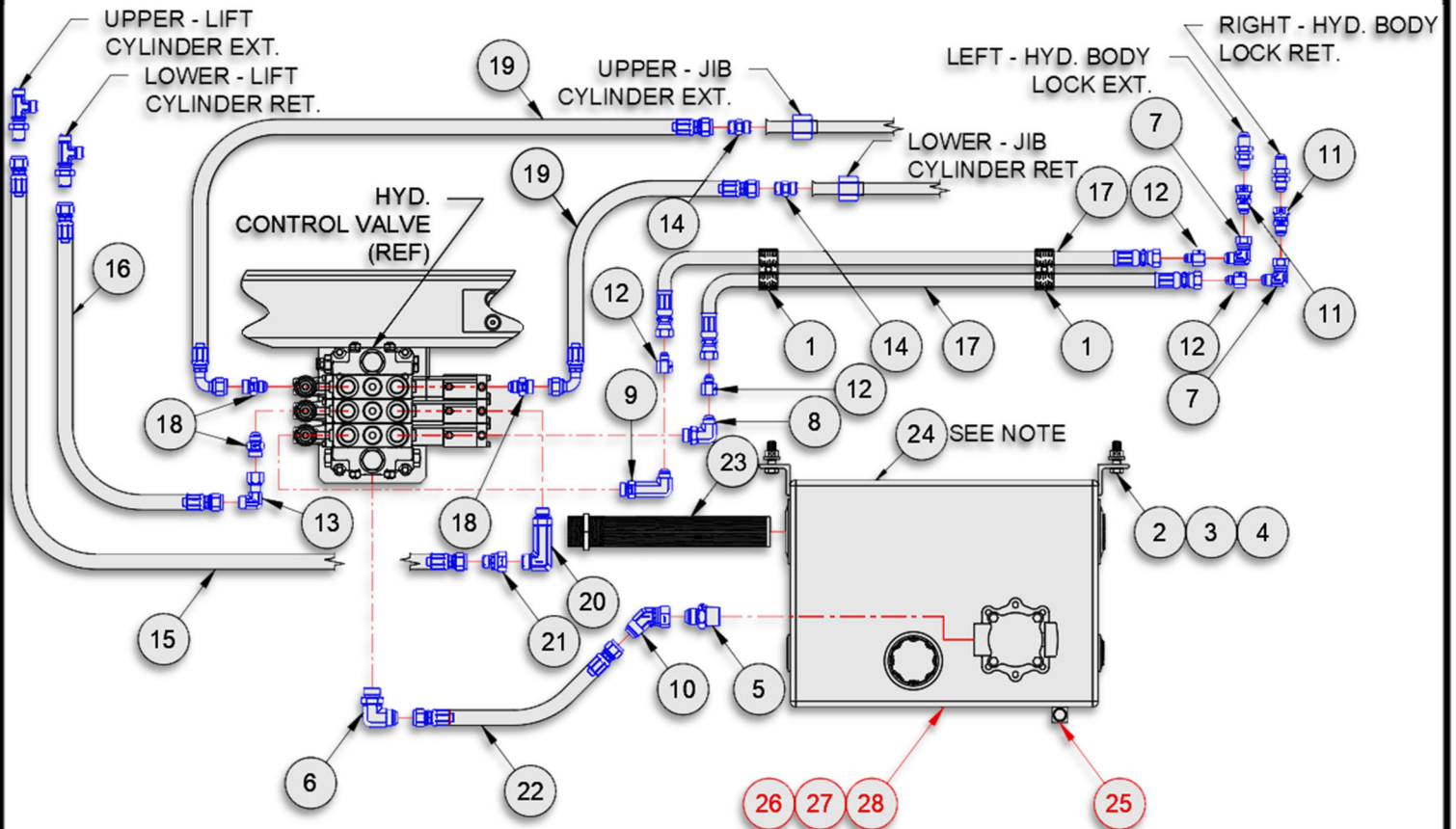

TANK CIRCUIT, 3-SECTION 520X

HEX HEAD CAP SCREW TORQUE SPECS	
BOLT SIZE	SAE GR 8 W/ LOCK WASHER (FT-LBS)
3/8	53
7/16	85
1/2	130
5/8	258
3/4	459
7/8	739
1	1108

Note: Apply Loctite 243 (Blue) to all bolts.

DRR-XHD – DUAL REAR ROLLER ASSEMBLY					X-HD	
ITEM	PART #	QTY	DESCRIPTION	WT-lb/ea.	WT-lb/all	
1	45H27	2	Roller Assy, Ø2-7/8 x 1-3/4ID	3.52	7.04	
2	45H28	2	Pin, DRR 1-3/4 x 4-1/8	2.99	5.98	
3	25H35	1	Lower Tie Plate, PJ 105	8.67	8.67	
4	00772	2	Washer, Flat 1/2	0.04	0.08	
5	00P01	2	HHCS 1/2-13 UNC x 1-1/2 Gr8	0.21	0.42	
6	00P35	2	Nut, Lock 1/2-13 UNC GrC	0.05	0.10	
7	02P06	2	Snap Ring, Ext 1.50	0.01	0.02	
8	90P03	2	Grease Zerk, 1/8-27 NPT Str	0.01	0.02	
BEARINGS						
9	50P14	2	Brz Brg, 1.75IDx3.00x2.13OD	1.00		

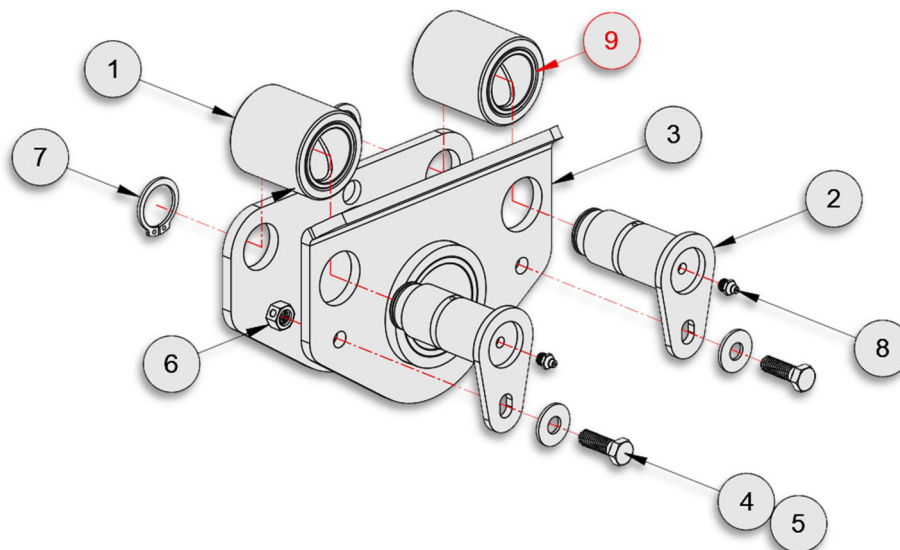

DUAL REAR ROLLER ASSEMBLY

HEX HEAD CAP SCREW TORQUE SPECS	
BOLT SIZE	SAE GR 8 W/ LOCK WASHER (FT-LBS)
3/8	53
7/16	85
1/2	130
5/8	258
3/4	459
7/8	739
1	1108

Note: Apply Loctite 243 (Blue) to all bolts.

42H62 – STABILIZER ASSEMBLY					SL-520X	
ITEM	PART #	QTY	DESCRIPTION	WT-lb/ea.	WT-lb/all	
1	42H63	1	Stabilizer Mnt Wdmt	229.01	229.01	
2	42H64	1	Stabilizer Arm	64.70	64.70	
3	42H65	1	Stabilizer Roller Wdmt	78.10	78.10	
4	86H65	1	Pin, Stabilizer 1 x 6-3/4	1.60	1.60	
5	86H66	1	Pin, Stabilizer 1 x 3-3/4	0.90	0.90	
6	86H67	1	Pin, Stabilizer 1 x 32	39.40	39.40	
7	86H68	1	Pin, Stabilizer 2-3/8x21-1/4	26.20	26.20	
8	86H69	2	End Plate, Stabilizer	0.70	1.40	
9	86H70	2	Gusset, Stabilizer	5.45	10.90	
10	90H83	1	Stabilizer Circuit	21.20	21.20	
11	00755	4	Washer, Lock - 3/8 Dia	0.03	0.12	
12	00787	4	Washer, Flat - 1 Dia HT	0.19	0.76	
13	00P03	4	HHCS 3/8-16 UNC x 3/4 Gr8	0.04	0.16	
14	00P55	1	Nut, Lock 5/8-11 UNC Gr8	0.13	0.13	
15	00P98	4	Pin, Cotter 5/32 x 1-1/2	0.01	0.04	
16	01P39	1	HHCS 5/8-11 UNC x 4-1/2 Gr8	0.49	0.49	
17	21P84	1	Hyd Cyl 3x1.375x6	35.00	35.00	
18	90P03	4	Zerk, Grease - 1/8 NPT	0.01	0.04	

* Item not shown. See Pg. 4-10

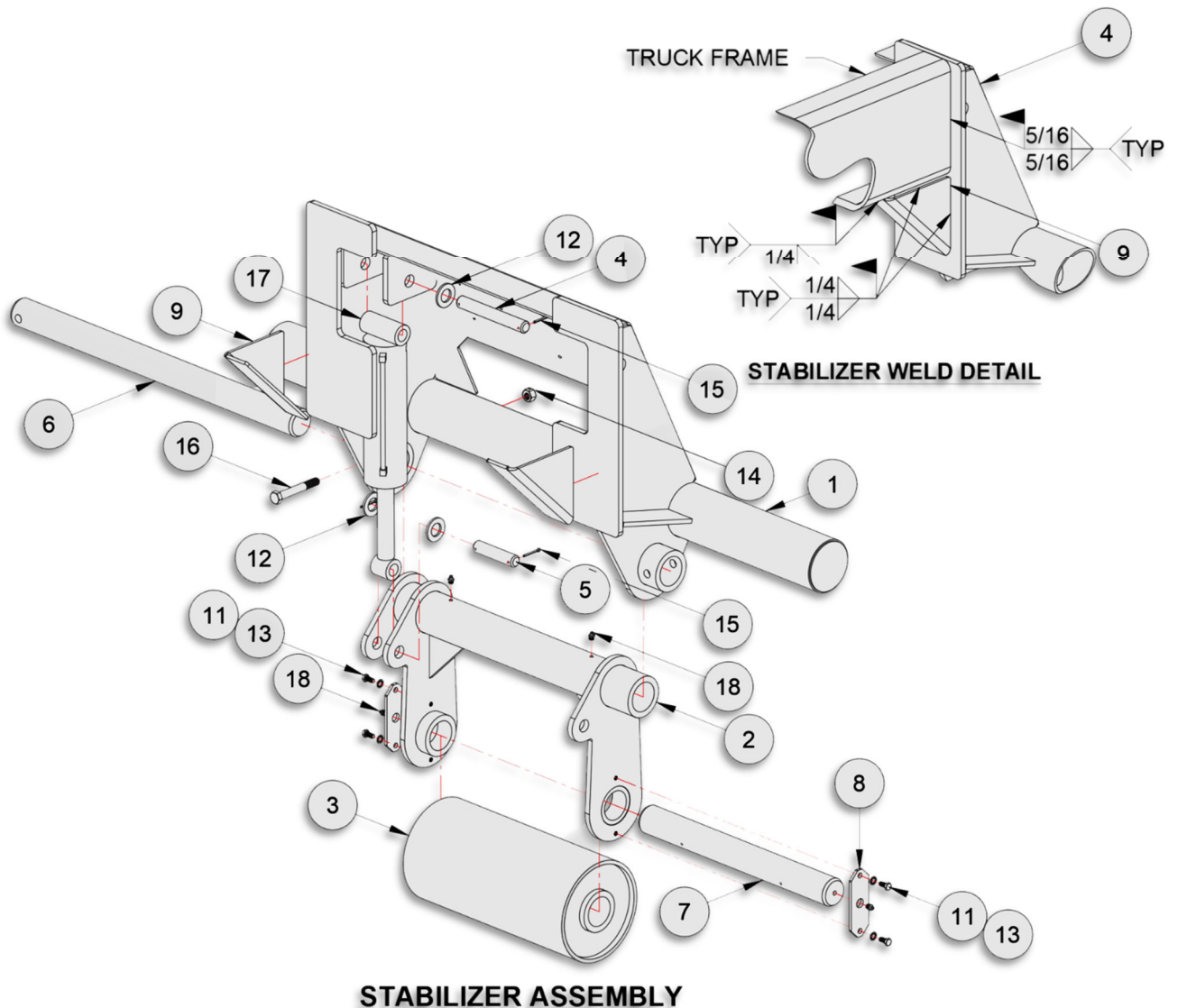

90H83 – STABILIZER CIRCUIT				SL-520X	
ITEM	PART #	QTY	DESCRIPTION	WT-lb/ea.	WT-lb/all
1	10P44	1	Adp Hyd 08MJ/08FJ 90	0.30	0.30
2	11P83	1	Adp Hyd 08MJ/12MB	0.40	0.40
3	11P84	1	Adp Hyd 08MJ/12MB 90	0.40	0.40
4	11P87	2	Hose Assy 243.5 08FJ/08FJ45	8.00	16.00
5	11P89	2	Adp Hyd 08MJ/06MP	0.40	0.80

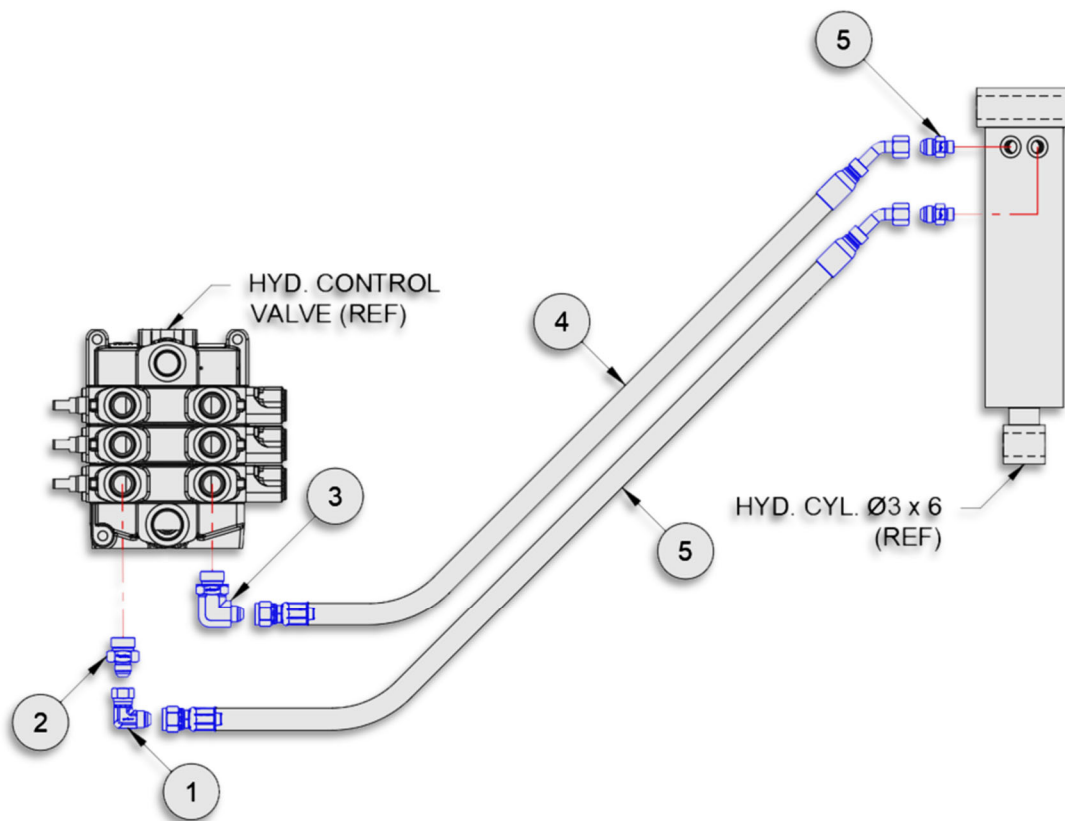

STABILIZER CIRCUIT

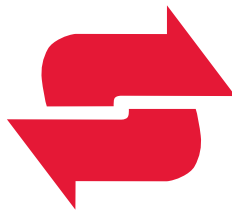

An EFCO Company

SWAPLOADER[®]
"Hooked on Quality"

U.S.A. LTD.

1800 NE BROADWAY AVENUE

DES MOINES, IA 50313

TOLL FREE: 888-767-8000