

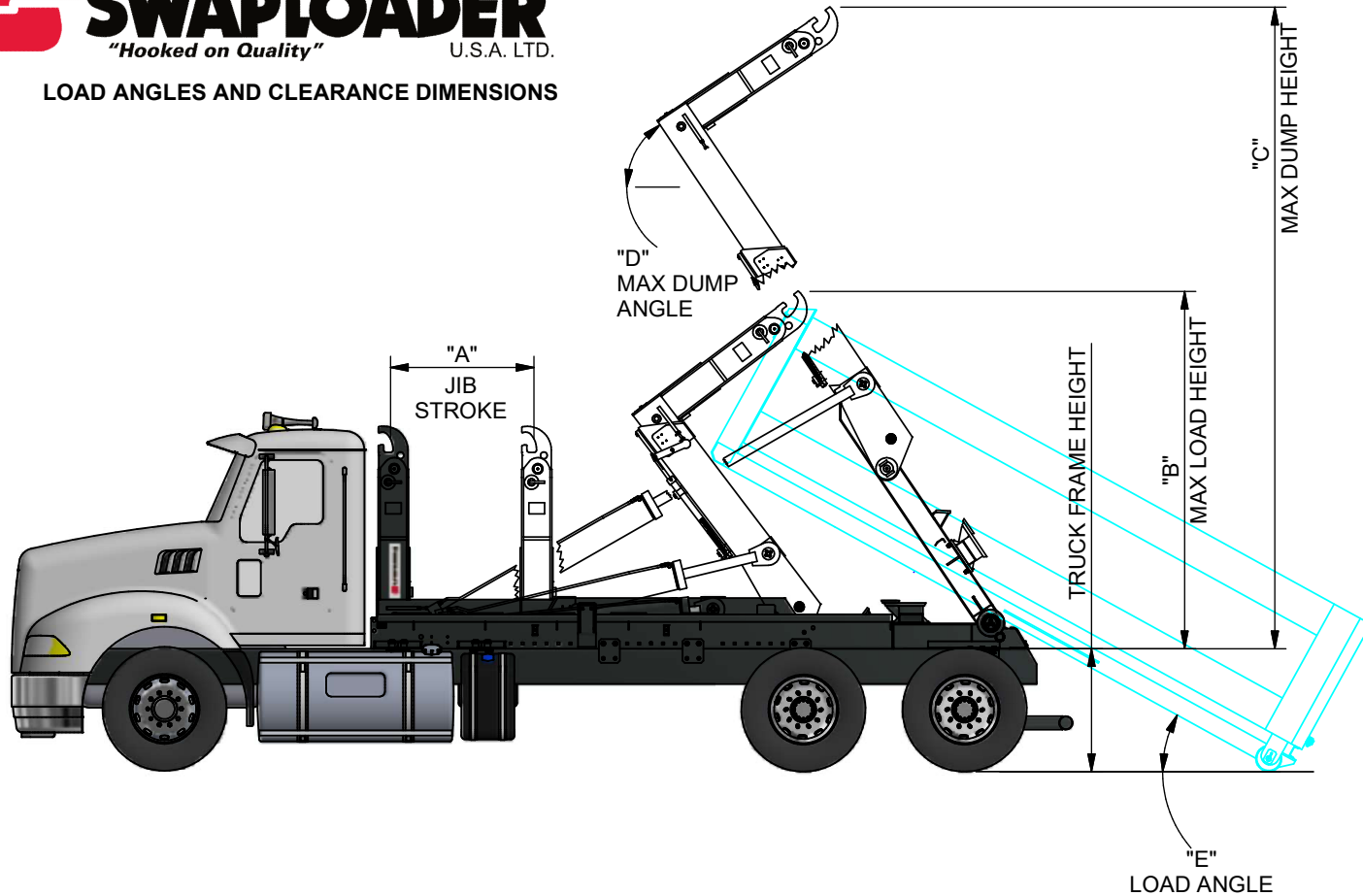

LOAD ANGLES AND CLEARANCE DIMENSIONS



LOAD ANGLES		
MODEL	SUB-FRAME	E
SL-75	9 FT	45°
	13 FT	28°
SL-105	10 FT	39°
	13 FT	28°
SL-160	12 FT	41°
	15 FT	29°
SL-212	12 FT	41°
	16 FT	26°
SL-214	14 FT	32°
	16 FT	27°
	18 FT	23°
SL-220	18 FT	30°
	22 FT	21°
SL-222	16 FT	36°
	20 FT	25°
SL-240	14 FT	35°
	18 FT	26°
SL-2418HD	10 FT	40°
	13 FT	30°
SL-330/400	14 FT	35°
	18 FT	26°
SL-412	12 FT	39°
	16 FT	31°
SL-418X	14 FT	37°
	22 FT	22°
SL-518X	14 FT	37°
	22 FT	22°
SL-520X	19 FT	30°
	24 FT	23°
SL-650	20 FT	28°
	24 FT	21°

100 SERIES CLEARANCE DIMENSIONS

Model	A	B 36"/54"	C 36"/54"	D
SL-75	20"	79" / NA	125" / NA	56°
SL-105	24"	81" / NA	131" / NA	58°
SL-160	32"	89" / 101"	148" / 159"	56°
SL-212	32"	89" / 101"	151" / 161"	58°
SL-214	36"	85" / 97"	165" / 176"	58°

400 / HD SERIES CLEARANCE DIMENSIONS

Model	A	B 54"/62"	C 54"/62"	D
SL-330/400	38"	115" / 120"	189" / 192"	57°
SL-412	30"	110" / 115"	170" / 174"	60°
SL-418X	48"	120" / 124"	218" / 222"	58°
SL-518X	48"	120" / 124"	218" / 222"	58°
SL-520X	52"	131" / 135"	239" / 242"	60°
SL-650	52"	NA / 134"	NA / 255"	54°

200 SERIES CLEARANCE DIMENSIONS

Model	A	B 54"/62"	C 54"/62"	D
SL-220	48"	124" / 128"	206" / 209"	53°
SL-222	34"	124" / 128"	195" / 198"	53°
SL-240	30"	108" / 112"	179" / 182"	53°
SL-2418HD	24"	97" / NA	145" / NA	53°

* ADD TRUCK FRAME HEIGHT TO DIMENSIONS B & C
 * DIMENSIONS ARE ROUNDED UP TO THE NEAREST WHOLE NUMBER
 * TRUCK FRAME HEIGHT IN DRAWING USES 35" FOR SL-105/75 & 41"
 FOR ALL OTHER MODELS

S788 4/3/2024- REV F

Load Angles and Clearance Dimensions

All Models

S788